

12-BIT, 200-KSPS, 11 CHANNEL, LOW POWER, SERIAL ADC WITH INTERNAL REFERENCE

FEATURES

- 12-Bit-Resolution A/D Converter
- Up to 200-KSPS (150-KSPS for 3 V) Throughput Bit With 12-Output Mode Over Operating Temperature Range
- 11 Analog Input Channels
- 3 Built-In Self-Test Modes
- Programmable Reference (2.048/4.096 V Internal, External)
- Inherent Sample and Hold Function
- Linearity Error . . . ± 1 LSB Max
- On-Chip Conversion Clock
- Programmable Conversion Status Output: $\overline{\text{INT}}$ or EOC
- Unipolar or Bipolar Output Operation
- Programmable MSB or LSB First
- Programmable Power Down
- Programmable Output Data Length
- SPI Compatible Serial Interface With I/O Clock Frequencies up to 15 MHz (CPOL=0, CPHA=0)

In addition to the high-speed converter and versatile control capability, the device has an on-chip 14-channel multiplexer that can select any one of 11 inputs or any one of three internal self-test voltages using configuration register 1. The sample-and-hold function is automatic. At the end of conversion, when programmed as EOC, the pin 19 output goes high to indicate that conversion is complete. If pin 19 is programmed as $\overline{\text{INT}}$, the signal goes low when the conversion is complete. The converter incorporated in the device features differential, high-impedance reference inputs that facilitate ratiometric conversion, scaling, and isolation of analog circuitry from logic and supply noise. A switched-capacitor design allows low-error conversion over the full operating temperature range. An internal reference is available and its voltage level is programmable via configuration register 2 (CFGR2).

The TLV2556I is characterized for operation from $T_A = -40^\circ\text{C}$ to 85°C . See available options table for package options.

APPLICATIONS

- Industrial Process Control
- Portable Data Logging
- Battery Powered Instruments
- Automotive

DESCRIPTION

The TLV2556 is a 12-bit, switched-capacitor, successive-approximation, analog-to-digital converter. The ADC has three control inputs [chip select ($\overline{\text{CS}}$), the input-output clock, and the address/control input (DATAIN)], designed for communication with the serial port of a host processor or peripheral through a serial 3-state output.

PW AND DW PACKAGE
(TOP VIEW)

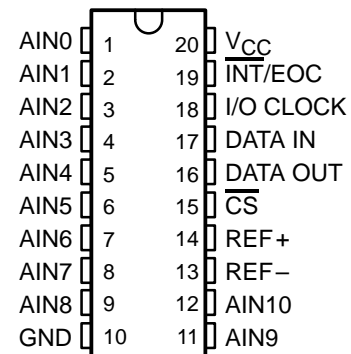

Please be aware that an important notice concerning availability, standard warranty, and use in critical applications of Texas Instruments semiconductor products and disclaimers thereto appears at the end of this data sheet.

PRODUCTION DATA information is current as of publication date. Products conform to specifications per the terms of Texas Instruments standard warranty. Production processing does not necessarily include testing of all parameters.

TLV2556

SLAS355A – DECEMBER 2001 – REVISED SEPTEMBER 2002

AVAILABLE OPTIONS

T _A	PACKAGE	
	SMALL OUTLINE	
	20-TSSOP (PW)	20-SOWB (DW)
-40°C to 85°C	TLV2556IPW	TLV2556IDW

functional block diagram

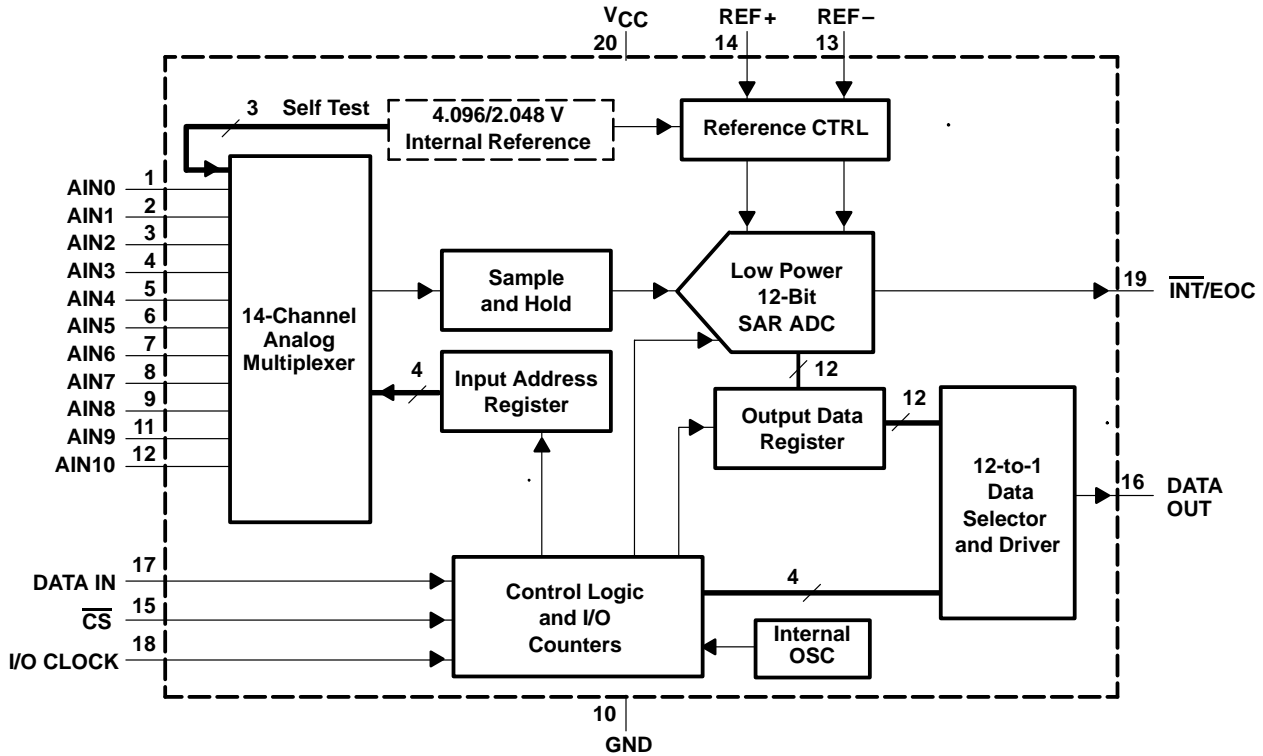

Terminal Functions

TERMINAL NAME	NO.	I/O	DESCRIPTION
AIN0 – AIN10	1–9, 11, 12	I	Analog input. These 11 analog-signal inputs are internally multiplexed.
$\overline{\text{CS}}$	15	I	Chip select. A high-to-low transition on $\overline{\text{CS}}$ resets the internal counters and controls and enables DATA OUT, DATA IN, and I/O CLOCK. A low-to-high transition disables DATA IN and I/O CLOCK within a setup time.
DATA IN	17	I	Serial data input. The 4-bit serial data can be used as address selects the desired analog input channel or test voltage to be converted next, or a command to activate other other features. The input data is presented with the MSB (D7) first and is shifted in on the first four rising edges of the I/O CLOCK. After the four address/command bits are read into the command register CMR, I/O CLOCK clocks the remaining four bits of configuration in.
DATA OUT	16	O	The 3-state serial output for the A/D conversion result. DATA OUT is in the high-impedance state when $\overline{\text{CS}}$ is high and active when $\overline{\text{CS}}$ is low. With a valid $\overline{\text{CS}}$, DATA OUT is removed from the high-impedance state and is driven to the logic level corresponding to the MSB(most significant bit)/LSB(least significant bit) value of the previous conversion result. The next falling edge of I/O CLOCK drives DATA OUT to the logic level corresponding to the next MSB/LSB, and the remaining bits are shifted out in order.
$\overline{\text{INT}}/\text{EOC}$	19	O	Status output, used to indicate the end of conversion (EOC) or an interrupt (INT) to host processor. Programmed as INT (interrupt): INT goes from a high to a low logic level after the conversion is complete and the data is ready for transfer. INT is cleared by a rising I/O CLOCK transition. Programmed as EOC: EOC goes from a high to a low logic level after the falling edge of the last I/O CLOCK and remains low until the conversion is complete and the data is ready for transfer.
GND	10		Ground. GND is the ground return terminal for the internal circuitry. Unless otherwise noted, all voltage measurements are with respect to GND.
I/O CLOCK	18	I	Input/output clock. I/O CLOCK receives the serial input and performs the following four functions: 1. It clocks the eight input data bits into the input data register on the first eight rising edges of I/O CLOCK with the multiplexer address available after the fourth rising edge. 2. On the fourth falling edge of I/O CLOCK, the analog input voltage on the selected multiplexer input begins charging the capacitor array and continues to do so until the last falling edge of I/O CLOCK. 3. The remaining 11 bits of the previous conversion data are shifted out on DATA OUT. Data changes on the falling edge of I/O CLOCK. 4. Control of the conversion is transferred to the internal state controller on the falling edge of the last I/O CLOCK.
REF+	14	I/O	Positive reference voltage The upper reference voltage value (nominally V_{CC}) is applied to REF+. The maximum analog input voltage range is determined by the difference between the voltage applied to terminals REF+ and REF–. When the internal reference is used it is capable of driving a 10-k Ω , 10-pF load.
REF–	13	I/O	Negative reference voltage. The lower reference voltage value (nominally ground) is applied to REF–. This pin is connected to analog ground (GND of the ADC) when the internal reference is used.
VCC	20		Positive supply voltage

TLV2556

SLAS355A – DECEMBER 2001 – REVISED SEPTEMBER 2002

absolute maximum ratings over operating free-air temperature range (unless otherwise noted)†

Supply voltage range, V_{CC} (see Note 1)	–0.5 V to 6.5 V
Input voltage range, V_I (any input)	–0.3 V to $V_{CC} + 0.3$ V
Output voltage range, V_O	–0.3 V to $V_{CC} + 0.3$ V
Positive reference voltage range, V_{ref+}	–0.3 V to $V_{CC} + 0.3$ V
Negative reference voltage range, V_{ref-}	–0.3 V to $V_{CC} + 0.3$ V
Peak input current, I_I (any input)	±20 mA
Peak total input current (all inputs)	±30 mA
Operating virtual junction temperature range, T_J	–40°C to 150°C
Operating free-air temperature range, T_A	–40°C to 85°C
Storage temperature range, T_{stg}	–65°C to 150°C
Lead temperature 1,6 mm (1/16 inch) from the case for 10 seconds	260°C

† Stresses beyond those listed under “absolute maximum ratings” may cause permanent damage to the device. These are stress ratings only, and functional operation of the device at these or any other conditions beyond those indicated under “recommended operating conditions” is not implied. Exposure to absolute-maximum-rated conditions for extended periods may affect device reliability.

NOTE 1: All voltage values are with respect to the GND terminal with REF– and GND wired together (unless otherwise noted).

recommended operating conditions

PARAMETERS		MIN	NOM	MAX	UNIT
Supply voltage, V_{CC}		2.7		5.5	V
SCLK frequency	$V_{CC} = 4.5$ V to 5.5 V	16-bit I/O	0.01	15	MHz
		12-bit I/O	0.01	15	
		8-bit I/O	0.01	15	
	$V_{CC} = 2.7$ V to 3.6 V	0.01	10		
Tolerable clock jitter, I/O CLOCK	$V_{CC} = 4.5$ V to 5.5 V			0.38	ns
Aperture jitter	$V_{CC} = 4.5$ V to 5.5 V		100		ps
Analog input voltage (see Note 2)	$V_{CC} = 4.5$ V to 5.5 V	0	(REF+) – (REF–)		V
	$V_{CC} = 3.0$ V to 3.6 V	0	(REF+) – (REF–)		
	$V_{CC} = 2.7$ V to 3.0 V	0	(REF+) – (REF–)		
High-level control input voltage, V_{IH}	$V_{CC} = 4.5$ V to 5.5 V	2.0			V
	$V_{CC} = 2.7$ V to 3.6 V	2.1			
Low-level control input voltage, V_{IL}	$V_{CC} = 4.5$ V to 5.5 V			0.8	V
	$V_{CC} = 2.7$ V to 3.6 V			0.6	
Operating free-air temperature, T_A	TLV2556I	–40		85	°C

NOTE 2: Analog input voltages greater than the voltage applied to REF+ convert as all ones (1111111111), while input voltages less than the voltage applied to REF– convert as all zeros (0000000000).

electrical characteristics over recommended operating free-air temperature range, $V_{REF+} = 5\text{ V}$, SCLK frequency = 15 MHz when $V_{CC} = 5\text{ V}$, $V_{REF+} = 2.5\text{ V}$, SCLK frequency = 10 MHz when $V_{CC} = 2.7\text{ V}$ (unless otherwise noted)

PARAMETER		TEST CONDITIONS		MIN	TYP†	MAX	UNIT
V _{OH}	High-level output voltage	V _{CC} = 4.5 V, I _{OH} = -1.6 mA	30 pF	2.4			V
		V _{CC} = 2.7 V, I _{OH} = -0.2 mA					
V _{OL}	Low-level output voltage	V _{CC} = 4.5 V, I _{OL} = -20 μA	30 pF	V _{CC} - 0.1			V
		V _{CC} = 2.7 V, I _{OL} = -20 μA					
V _{OL}	Low-level output voltage	V _{CC} = 5.5 V, I _{OL} = 1.6 mA	30 pF			0.4	V
		V _{CC} = 3.6 V, I _{OL} = 0.8 mA					
I _{OZ}	High-impedance off-state output current	V _O = V _{CC} , $\overline{\text{CS}}$ at V _{CC}			1 2.5		μA
		V _O = 0 V, $\overline{\text{CS}}$ at V _{CC}			-1 -2.5		
I _{CC}	Operating supply current	$\overline{\text{CS}}$ at 0 V, Ext. Ref	V _{CC} = 5 V			1.2	mA
			V _{CC} = 2.7 V			0.9	
		$\overline{\text{CS}}$ at 0 V, Int. Ref	V _{CC} = 5 V			3	
			V _{CC} = 2.7 V			2.4	
I _{CC} (SPD)	Software power-down current	For all digital inputs, 0 V ≤ V _I ≤ 0.5 V or V _I ≥ V _{CC} - 0.5 V, SCLK = 0 V	Ext. Ref	0.1 1		μA	
			Int. Ref	0.1 1			
I _{CC} (APD)	Auto power-down current	For all digital inputs, 0 V ≤ V _I ≤ 0.5 V or V _I ≥ V _{CC} - 0.5 V, SCLK = 0 V	Ext. Ref	0.1 10		μA	
			Int. Ref	1800			
I _{IH}	High-level input current	V _I = V _{CC}			0.005 2.5	μA	
I _{IL}	Low-level input current	V _I = 0 V			-0.005 -2.5	μA	
I _{Ikg}	Selected channel leakage current	Selected channel at V _{CC} , Unselected channel at 0 V			1	μA	
		Selected channel at 0 V, Unselected channel at V _{CC}			-1		
f(OSC)	Internal oscillator frequency	V _{CC} = 4.5 V to 5.5 V	3.27		MHz		
		V _{CC} = 2.7 V to 3.6 V	2.56				
t _{conv}	Conversion time = 13.5 × [f(OSC)] + 25 ns	V _{CC} = 4.5 V to 5.5 V	4.15		μs		
		V _{CC} = 2.7 V to 3.6 V	5.54				
	Internal oscillator frequency switch over voltage		3.6	4.1	V		
Z _i	Analog input MUX impedance‡	V _{CC} = 4.5 V	600		Ω		
		V _{CC} = 2.7 V	500				
C _i	Input capacitance	Analog inputs	45	55	pF		
		Control inputs	5	15			

† All typical values are at V_{CC} = 5 V, T_A = 25°C.

‡ The switch resistance is very nonlinear and varies with input voltage and supply voltage. This is the worst case.

TLV2556

SLAS355A – DECEMBER 2001 – REVISED SEPTEMBER 2002

external reference specifications

PARAMETER	TEST CONDITIONS	MIN	TYP†	MAX	UNIT
Reference input voltage, REF–	V _{CC} = 4.5 V to 5.5 V	–0.1	0	0.1	V
	V _{CC} = 2.7 V to 3.6 V	–0.1	0	0.1	
Reference input voltage, REF+	V _{CC} = 4.5 V to 5.5 V	2		V _{CC}	V
	V _{CC} = 2.7 V to 3.6 V	2		V _{CC}	
External reference input voltage difference, (REF+) – (REF–)	V _{CC} = 4.5 V to 5.5 V	1.9		V _{CC}	V
	V _{CC} = 2.7 V to 3.6 V	1.9		V _{CC}	
External reference supply current	\overline{CS} at 0 V	V _{CC} = 4.5 V to 5.5 V		1	mA
		V _{CC} = 2.7 V to 3.6 V		0.7	
Reference input impedance	V _{CC} = 5 V	Static	1		MΩ
		During sampling/conversion	6	9	kΩ
	V _{CC} = 2.7 V	Static	1		MΩ
		During sampling/conversion	6	9	kΩ

† All typical values are at V_{CC} = 5 V, T_A = 25°C.

NOTE: Add a 0.1-μF capacitor between REF+ and REF– pins when external reference is used.

internal reference specifications

PARAMETER	TEST CONDITIONS	MIN	TYP†	MAX	UNIT
Reference input voltage, REF–	V _{CC} = 2.7 V to 5.5 V, REF– = Analog GND		0		V
Internal reference delta voltage, (REF+) – (REF–)	V _{CC} = 5.5 V, Internal 4.096-V _{ref} selected	3.95	4.065	4.25	V
	V _{CC} = 5.5 V, Internal 2.048-V _{ref} selected	1.95	2.019	2.1	
	V _{CC} = 2.7 V, Internal 2.048-V _{ref} selected	1.95	2.019	2.1	
Internal reference start-up time	V _{CC} = 5 V		20		ms
	V _{CC} = 2.7 V		20		
Internal reference temperature coefficient	V _{CC} = 2.7 V to 5.5 V		±50		PPM/°C

† All typical values are at V_{CC} = 5 V, T_A = 25°C.

NOTE: When an internal reference is used, the following conditions are required:

- Add 0.1-μF and 10-μF capacitors between REF+ and REF– pins.
- REF– must be connected to analog GND (the ground pin of the ADC).

operating characteristics over recommended operating free-air temperature range, $V_{REF+} = 5\text{ V}$, SCLK frequency = 15 MHz when $V_{CC} = 5\text{ V}$, $V_{REF+} = 2.5\text{ V}$, SCLK frequency = 10 MHz when $V_{CC} = 2.7\text{ V}$ (unless otherwise noted)

PARAMETER		TEST CONDITIONS	MIN	TYP†	MAX	UNIT
INL	Integral nonlinearity error (see Note 3)		-1		1	LSB
DNL	Differential nonlinearity error		-1		1	LSB
E_O	Offset error (see Note 4)	See Note 2	-2		2	mV
E_G	Gain error (see Note 4)	See Note 2	-3		3	mV
E_T	Total unadjusted error (see Note 5)			±1.5		LSB
Self-test output code (see Table 2 and Note 6)		Address data input = 1011		2048		
		Address data input = 1100		0		
		Address data input = 1101		4095		

† All typical values are at $T_A = 25^\circ\text{C}$.

- NOTES:
- Analog input voltages greater than the voltage applied to REF+ convert as all ones (1111111111), while input voltages less than the voltage applied to REF- convert as all zeros (0000000000).
 - Linearity error is the maximum deviation from the best straight line through the A/D transfer characteristics.
 - Gain error is the difference between the actual midstep value and the nominal midstep value in the transfer diagram at the specified gain point after the offset error has been adjusted to zero. Offset error is the difference between the actual midstep value and the nominal midstep value at the offset point.
 - Total unadjusted error comprises linearity, zero-scale, and full-scale errors.
 - Both the input address and the output codes are expressed in positive logic.

timing characteristics over recommended operating free-air temperature range, $V_{REF+} = 5\text{ V}$, SCLK frequency = 15 MHz, $V_{CC} = 5\text{ V}$, load = 25 pF (unless otherwise noted)

PARAMETER		MIN	TYP	MAX	UNIT
t_{w1}	Pulse duration I/O CLOCK high or low	26.7		100000	ns
t_{su1}	Setup time DATA IN valid before I/O CLOCK rising edge (see Figure 38)	12			ns
t_{h1}	Hold time DATA IN valid after I/O CLOCK rising edge (see Figure 38)	0			ns
t_{su2}	Setup time \overline{CS} low before 1st rising I/O CLOCK edge (see Note 7 and Figure 39)	25			ns
t_{h2}	Hold time \overline{CS} pulse duration high time (see Figure 39)	100			ns
t_{h3}	Hold time \overline{CS} low after last I/O CLOCK falling edge (see Figure 39)	0			ns
t_{h4}	Hold time DATA OUT valid after I/O CLOCK falling edge (see Figure 40)	2			ns
t_{h5}	Hold time \overline{CS} high after EOC rising edge when \overline{CS} is toggled (see Figure 43)	0			ns
t_{h6}	Hold time \overline{CS} high after \overline{INT} falling edge (see Figure 43)	0			ns
t_{h7}	Hold time I/O CLOCK low after EOC rising edge or \overline{INT} falling edge when \overline{CS} is held low (see Figure 44)	10			ns
t_{d1}	Delay time \overline{CS} falling edge to DATA OUT valid (MSB or LSB) (see Figure 37)	Load = 25 pF		28	ns
		Load = 10 pF		20	
t_{d2}	Delay time \overline{CS} rising edge to DATA OUT high impedance (see Figure 37)			10	ns
t_{d3}	Delay time I/O CLOCK falling edge to next DATA OUT bit valid (see Figure 40)	2		20	ns
t_{d4}	Delay time last I/O CLOCK falling edge to EOC falling edge (see Figure 41)			55	ns
t_{d5}	Delay time last I/O CLOCK falling edge to \overline{CS} falling edge to abort conversion			1.5	μs
t_{d6}	Delay time last I/O CLOCK falling edge to \overline{INT} falling edge (see Figure 41)			MAX(t_{conv})	ns
t_{d7}	Delay time EOC rising edge or \overline{INT} falling edge to DATA OUT valid: MSB or LSB 1st (see Figure 42)			4	ns
t_{d9}	Delay time I/O CLOCK high to \overline{INT} rising edge when \overline{CS} is held low (see Figure 44)	1		28	ns
t_{t1}	Transition time I/O CLOCK (see Note 7 and Figure 40)			1	μs
t_{t2}	Transition time DATA OUT (see Figure 40)			5	ns
t_{t3}	Transition time \overline{INT} /EOC, C_L at 7 pF (see Figures 41 and 42)			2.4	ns
t_{t4}	Transition time DATA IN, \overline{CS}			10	μs
t_{cyc}	Total cycle time (sample, conversion and delays) (see Note 7)			MAX(t_{conv}) + I/O period (8/12/16 CLKs)	μs
t_{sample}	Channel acquisition time (sample), at 1 k Ω (see Note 7)	Source impedance = 25 Ω	600		ns
		Source impedance = 100 Ω	650		
		Source impedance = 500 Ω	700		
		Source impedance = 1 K Ω	1000		

NOTE 7: I/O CLOCK period = $8 \times [1/(I/O\text{ CLOCK frequency})]$ or $12 \times [1/(I/O\text{ CLOCK frequency})]$ or $16 \times [1/(I/O\text{ CLOCK frequency})]$ depends on I/O format selected.

timing characteristics over recommended operating free-air temperature range, $V_{REF+} = 2.5\text{ V}$, SCLK frequency = 10 MHz, $V_{CC} = 2.7\text{ V}$, load = 25 pF (unless otherwise noted)

PARAMETER		MIN	TYP	MAX	UNIT
t_{w1}	Pulse duration I/O CLOCK high or low	40		100000	ns
t_{su1}	Setup time DATA IN valid before I/O CLOCK rising edge (see Figure 38)	22			ns
t_{h1}	Hold time DATA IN valid after I/O CLOCK rising edge (see Figure 38)	0			ns
t_{su2}	Setup time \overline{CS} low before 1st rising I/O CLOCK edge (see Note 7 and Figure 39)	33			ns
t_{h2}	Hold time \overline{CS} pulse width high time (see Figure 39)	100			ns
t_{h3}	Hold time \overline{CS} low after last I/O CLOCK falling edge (see Figure 39)	0			ns
t_{h4}	Hold time DATA OUT valid after I/O CLOCK falling edge (see Figure 40)	2			ns
t_{h5}	Hold time \overline{CS} high after EOC rising edge when \overline{CS} is toggled (see Figure 43)	0			ns
t_{h6}	Hold time \overline{CS} high after \overline{INT} falling edge (see Figure 43)	0			ns
t_{h7}	Hold time I/O CLOCK low after EOC rising edge or \overline{INT} falling edge when \overline{CS} is held low (see Figure 44)	10			ns
t_{d1}	Delay time \overline{CS} falling edge to DATA OUT valid (MSB or LSB) (see Figure 37)	Load = 25 pF		30	ns
		Load = 10 pF		22	
t_{d2}	Delay time \overline{CS} rising edge to DATA OUT high impedance (see Figure 37)			10	ns
t_{d3}	Delay time I/O CLOCK falling edge to next DATA OUT bit valid (see Figure 40)	2		33	ns
t_{d4}	Delay time last I/O CLOCK falling edge to EOC falling edge (see Figure 41)			75	ns
t_{d5}	Delay time last I/O CLOCK falling edge to \overline{CS} falling edge to abort conversion			1.5	μs
t_{d6}	Delay time last I/O CLOCK falling edge to \overline{INT} falling edge (see Figure 41)			MAX(t_{conv})	ns
t_{d7}	Delay time EOC rising edge or \overline{INT} falling edge to DATA OUT valid: MSB or LSB 1st (see Figure 42)			20	ns
t_{d9}	Delay time I/O CLOCK high to \overline{INT} rising edge when \overline{CS} is held low (see Figure 44)			55	ns
t_{t1}	Transition time I/O CLOCK (see Note 7 and Figure 40)			1	μs
t_{t2}	Transition time DATA OUT (see Figure 40)			5	ns
t_{t3}	Transition time $\overline{INT}/\text{EOC}$, C_L at 7 pF (see Figures 41 and 42)			4	ns
t_{t4}	Transition time DATA IN, \overline{CS}			10	μs
t_{cyc}	Total cycle time (sample, conversion and delays) (see Note 7)			MAX(t_{conv}) + I/O period (8/12/16 CLKs)	μs
t_{sample}	Channel acquisition time (sample), at 1 k Ω (see Note 7)	Source impedance = 25 Ω	800		ns
		Source impedance = 100 Ω	850		
		Source impedance = 500 Ω	1000		
		Source impedance = 1K Ω	1600		

NOTE 7: I/O CLOCK period = $8 \times [1/(\text{I/O CLOCK frequency})]$ or $12 \times [1/(\text{I/O CLOCK frequency})]$ or $16 \times [1/(\text{I/O CLOCK frequency})]$ depends on I/O format selected.

TYPICAL CHARACTERISTICS

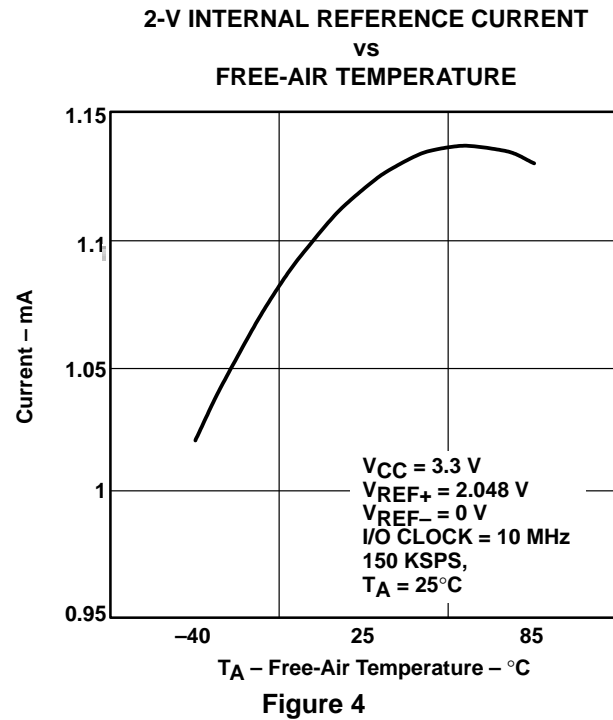
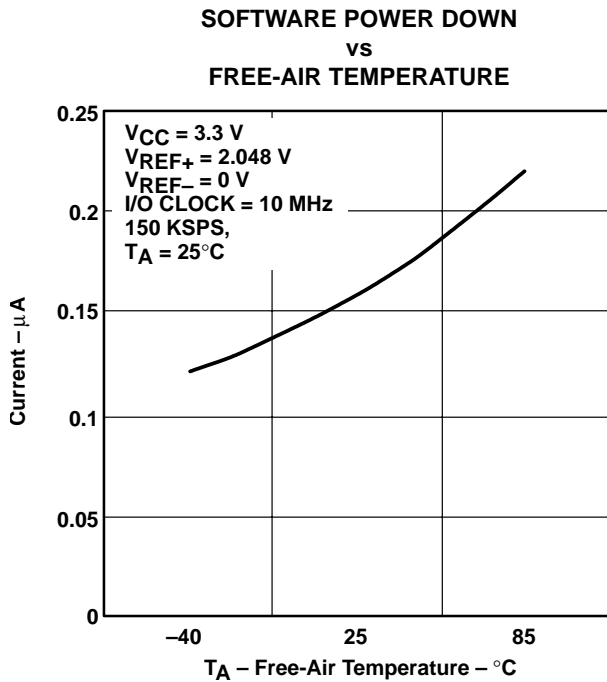
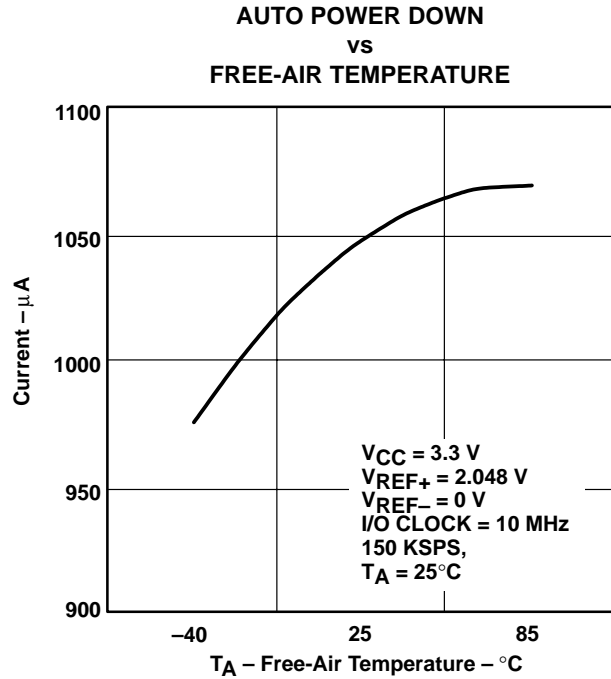
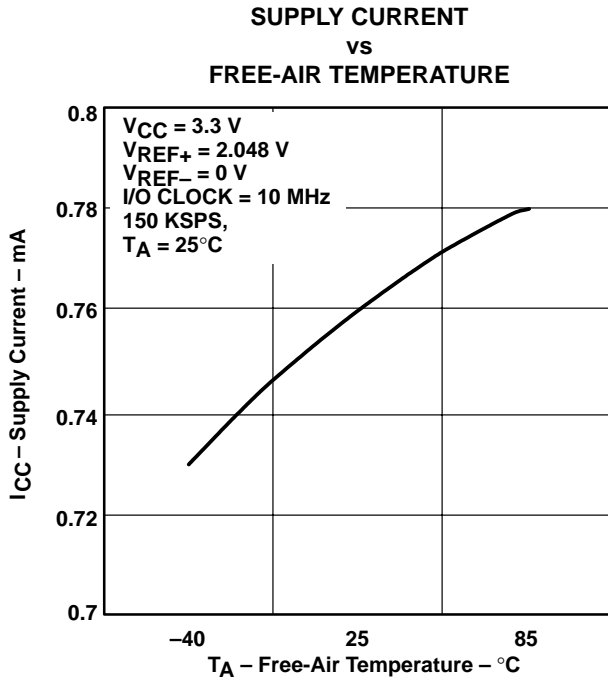

NOTE: All typical curves are with internal reference unless specified otherwise. Refer to the TLV2553 data sheet (SLAS354) for typical curves using an external reference.

TYPICAL CHARACTERISTICS

MAXIMUM DIFFERENTIAL NONLINEARITY
vs
FREE-AIR TEMPERATURE

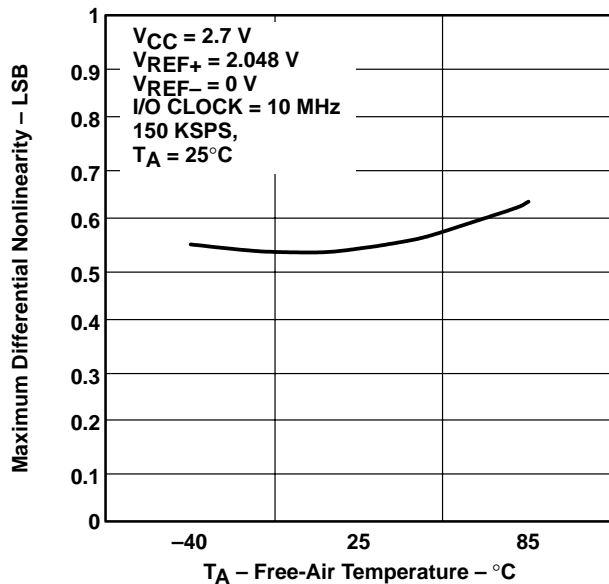

Figure 5

MINIMUM DIFFERENTIAL NONLINEARITY
vs
FREE-AIR TEMPERATURE

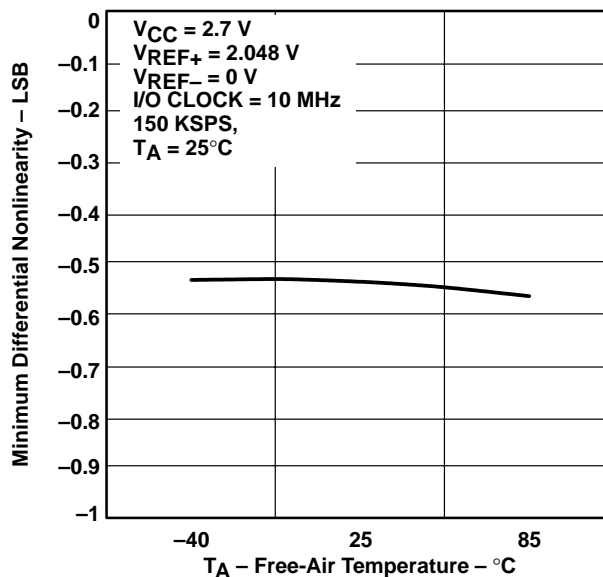

Figure 6

MAXIMUM INTEGRAL NONLINEARITY
vs
FREE-AIR TEMPERATURE

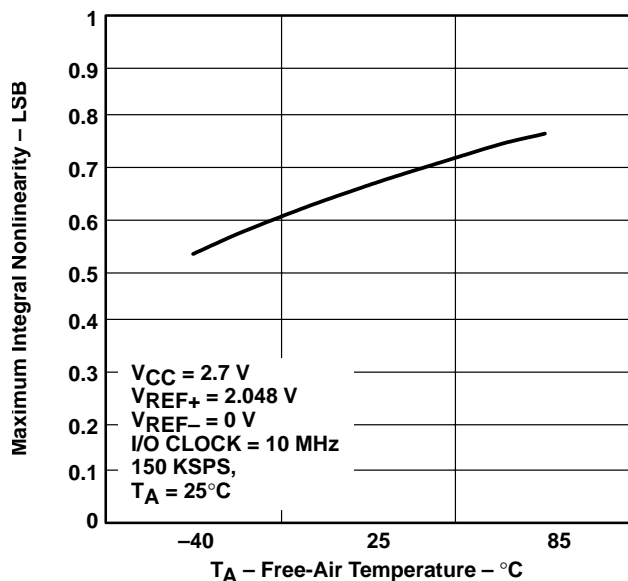

Figure 7

MINIMUM INTEGRAL NONLINEARITY
vs
FREE-AIR TEMPERATURE

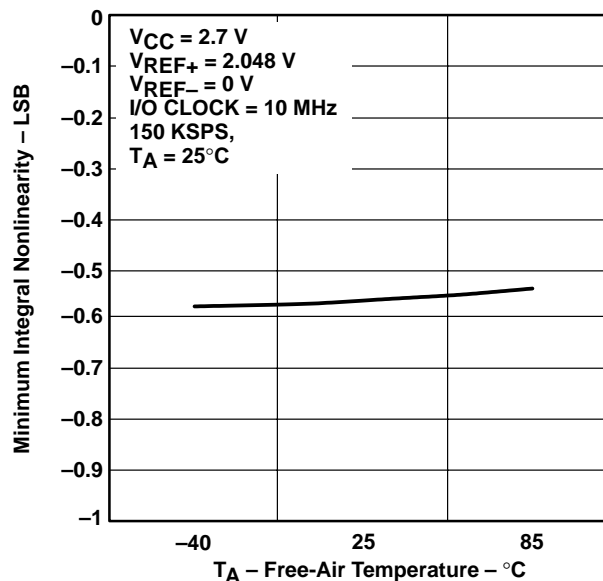

Figure 8

NOTE: All typical curves are with internal reference unless specified otherwise. Refer to the TLV2553 data sheet (SLAS354) for typical curves using an external reference.

TYPICAL CHARACTERISTICS

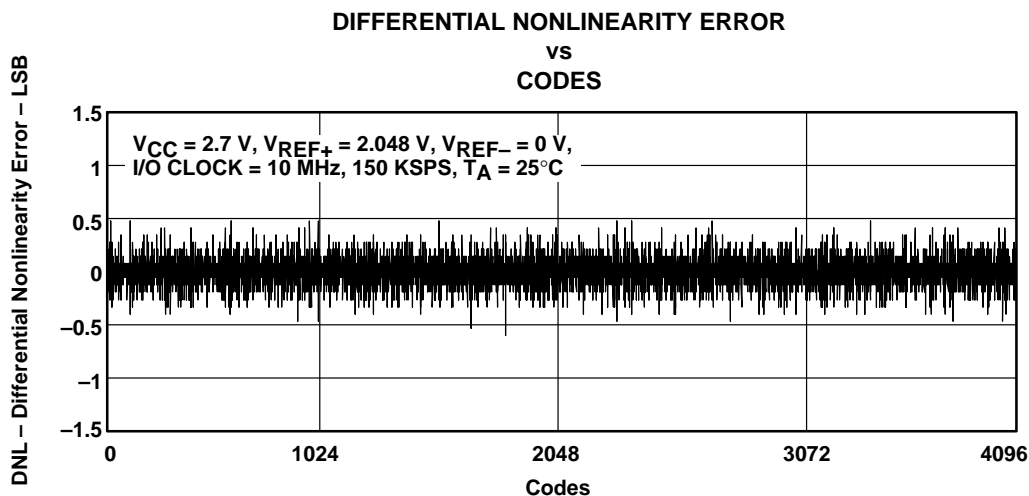

Figure 9

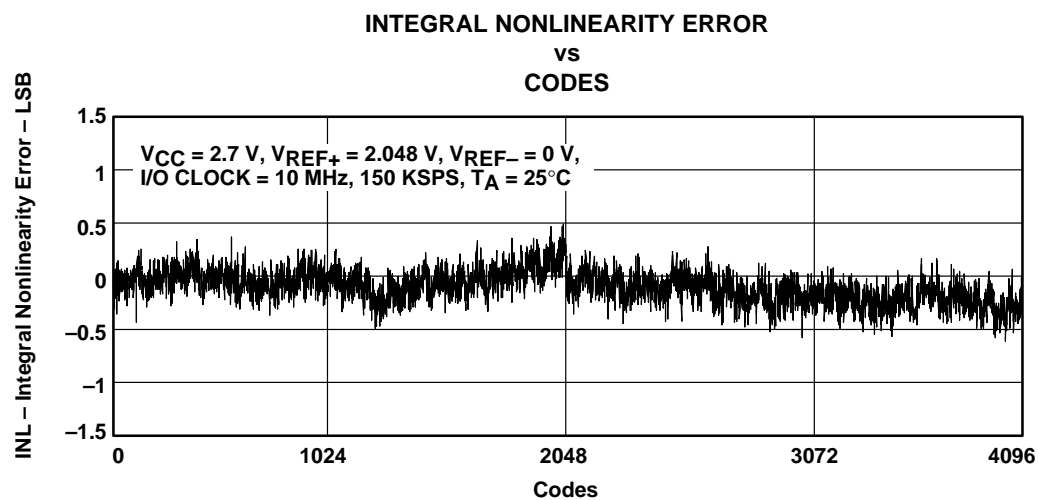
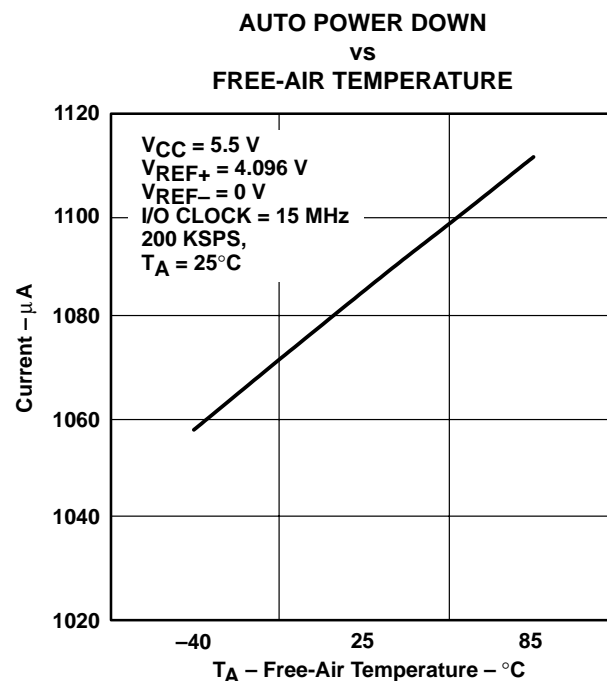
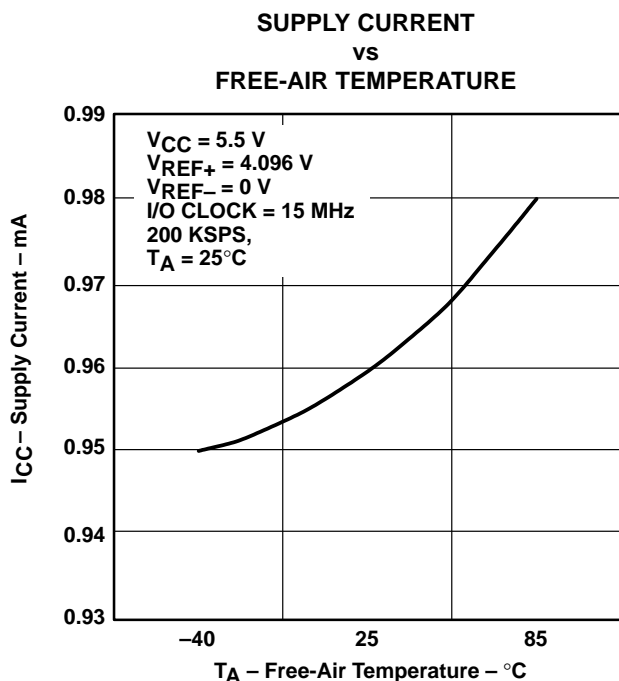
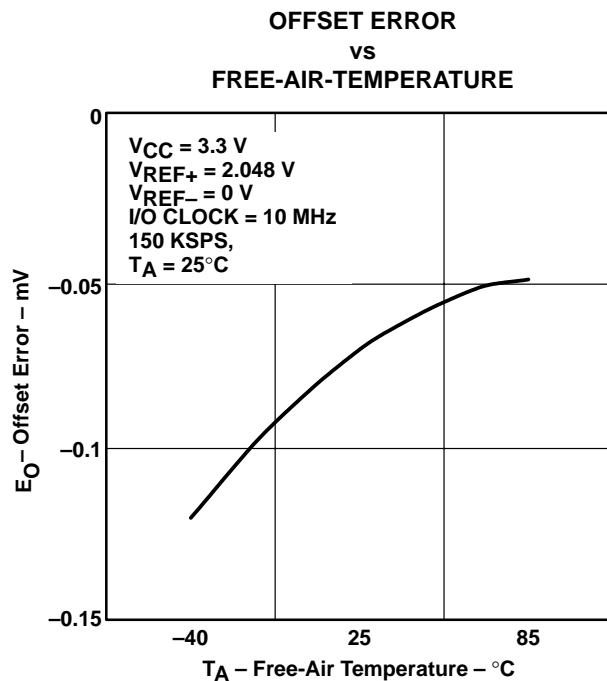
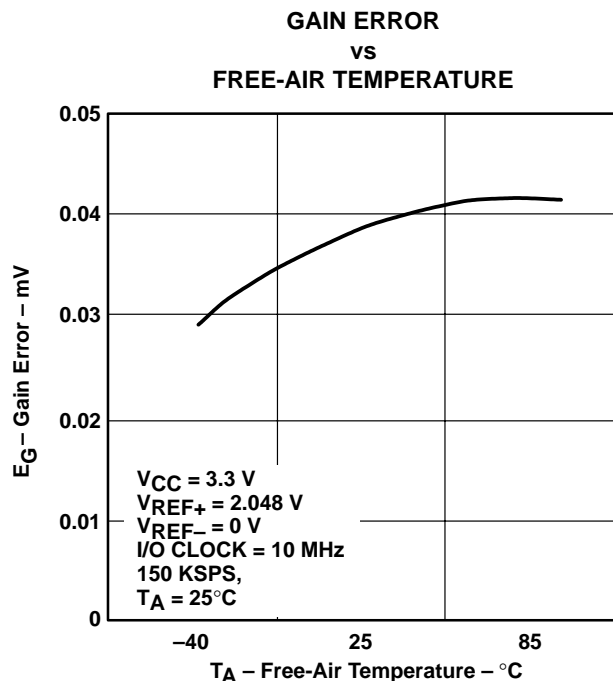

Figure 10

NOTE: All typical curves are with internal reference unless specified otherwise. Refer to the TLV2553 data sheet (SLAS354) for typical curves using an external reference.

TYPICAL CHARACTERISTICS



NOTE: All typical curves are with internal reference unless specified otherwise. Refer to the TLV2553 data sheet (SLAS354) for typical curves using an external reference.

TYPICAL CHARACTERISTICS

SOFTWARE POWER DOWN
vs
FREE-AIR TEMPERATURE

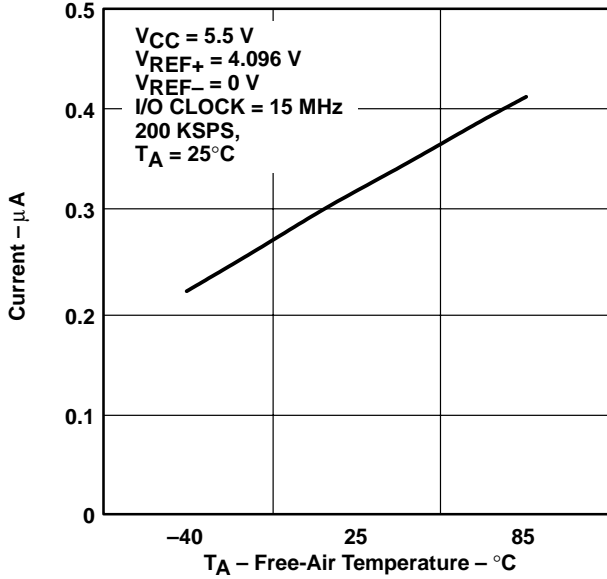

Figure 15

4-V INTERNAL REFERENCE CURRENT
vs
FREE-AIR TEMPERATURE

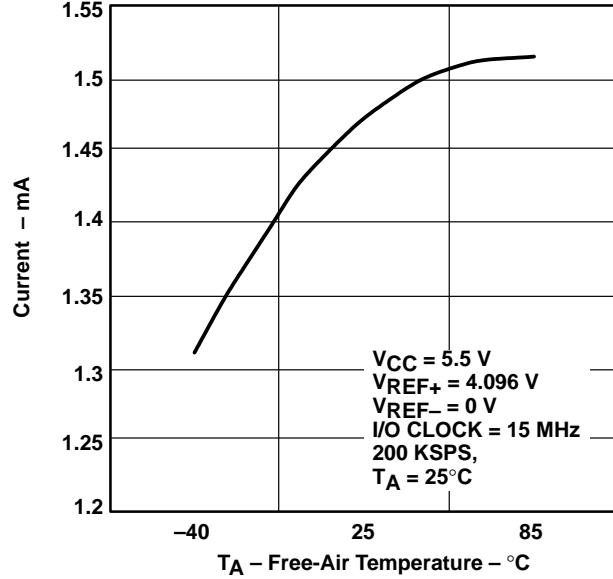

Figure 16

MAXIMUM DIFFERENTIAL NONLINEARITY
vs
FREE-AIR TEMPERATURE

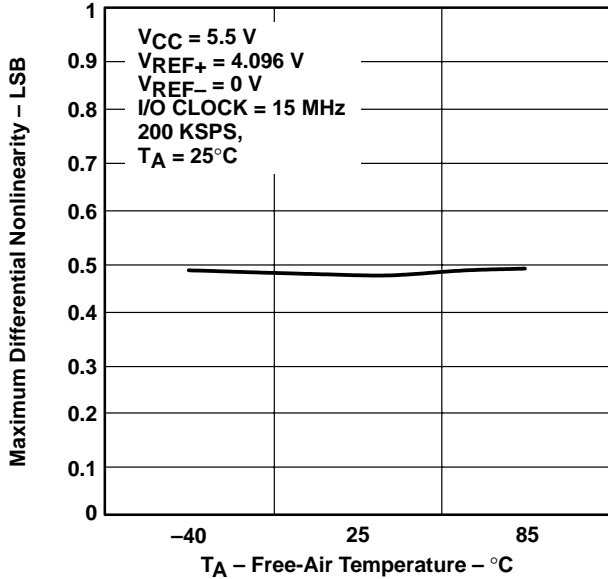

Figure 17

MINIMUM DIFFERENTIAL NONLINEARITY
vs
FREE-AIR TEMPERATURE

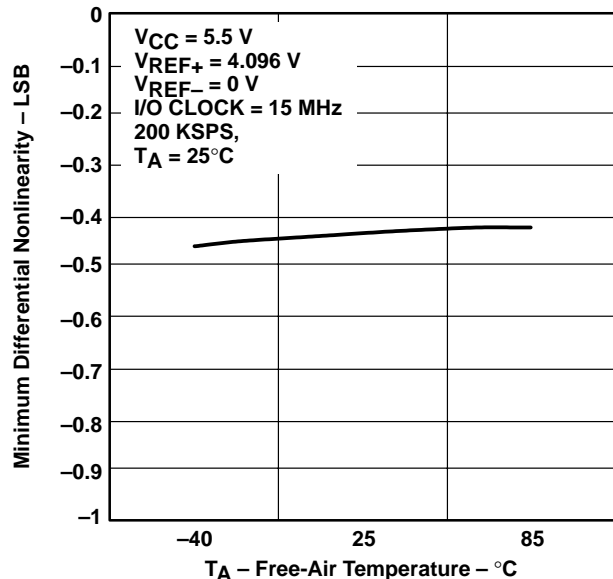
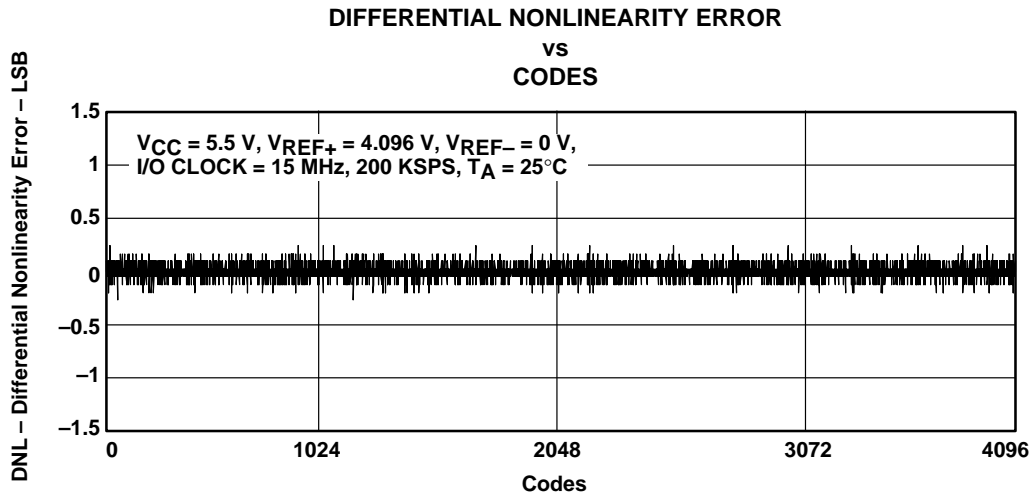
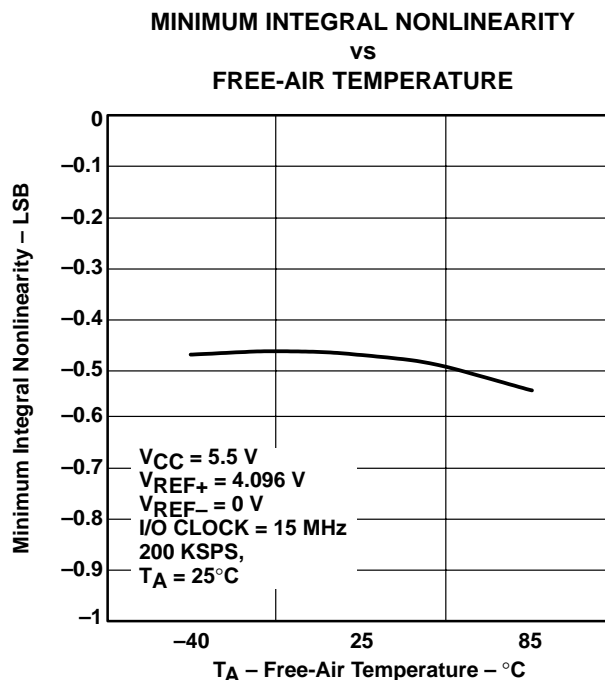
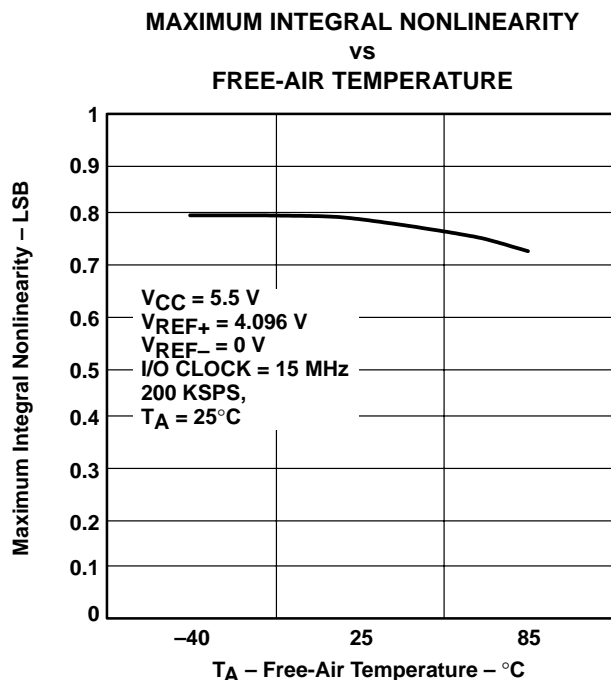

Figure 18

NOTE: All typical curves are with internal reference unless specified otherwise. Refer to the TLV2553 data sheet (SLAS354) for typical curves using an external reference.

TYPICAL CHARACTERISTICS



NOTE: All typical curves are with internal reference unless specified otherwise. Refer to the TLV2553 data sheet (SLAS354) for typical curves using an external reference.

TYPICAL CHARACTERISTICS

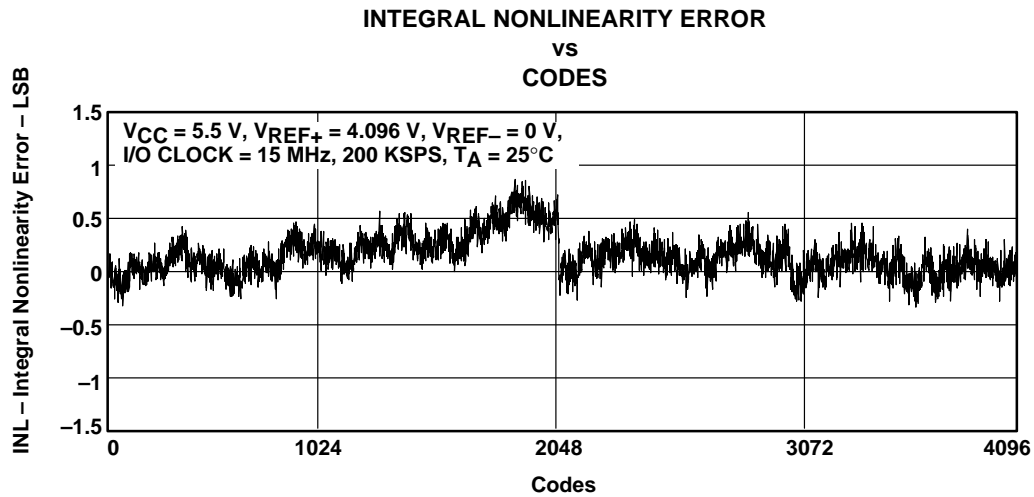

Figure 22

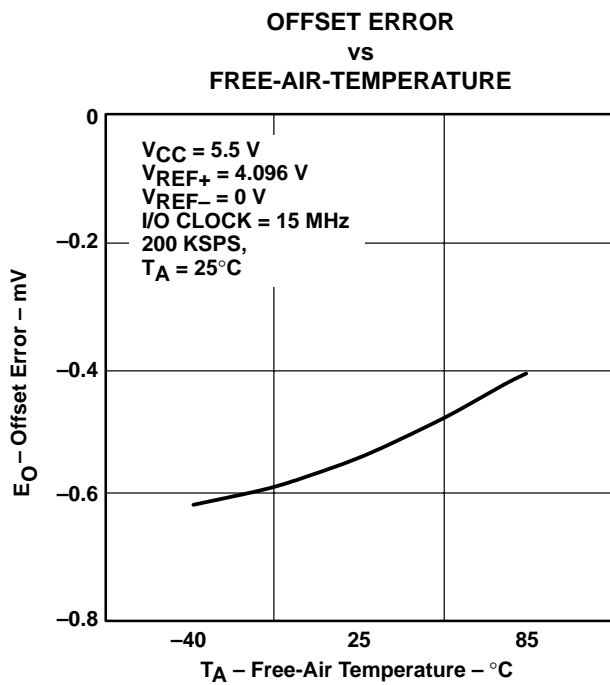

Figure 23

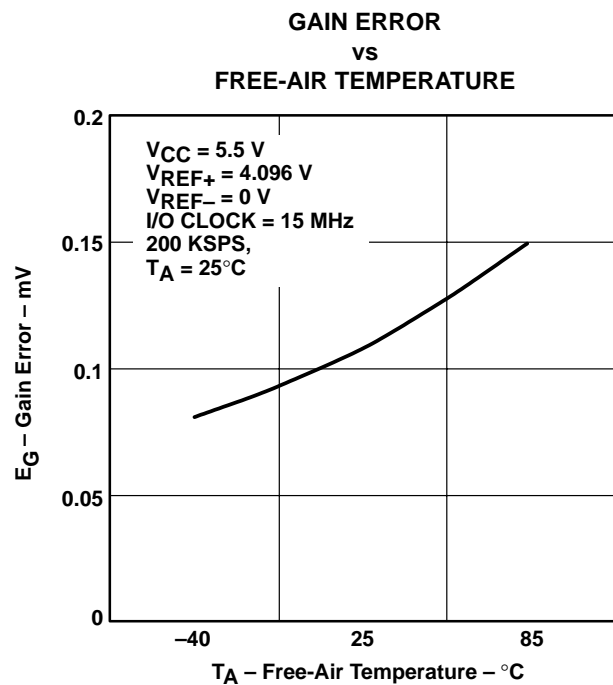

Figure 24

NOTE: All typical curves are with internal reference unless specified otherwise. Refer to the TLV2553 data sheet (SLAS354) for typical curves using an external reference.

TYPICAL CHARACTERISTICS

SUPPLY CURRENT
vs
FREE-AIR TEMPERATURE

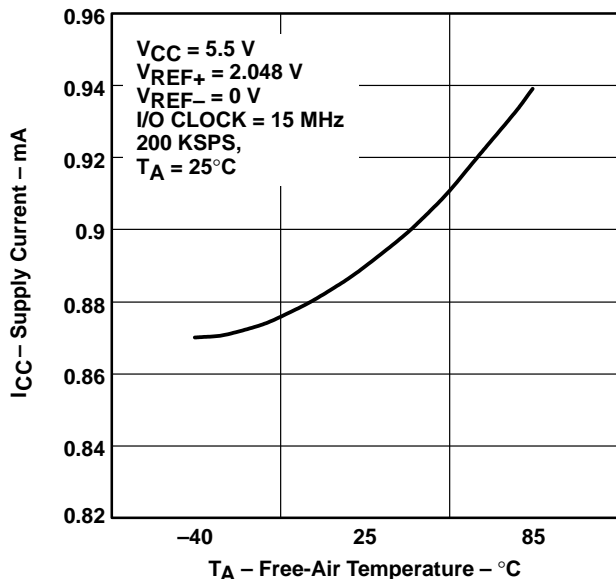

Figure 25

SOFTWARE POWER DOWN
vs
FREE-AIR TEMPERATURE

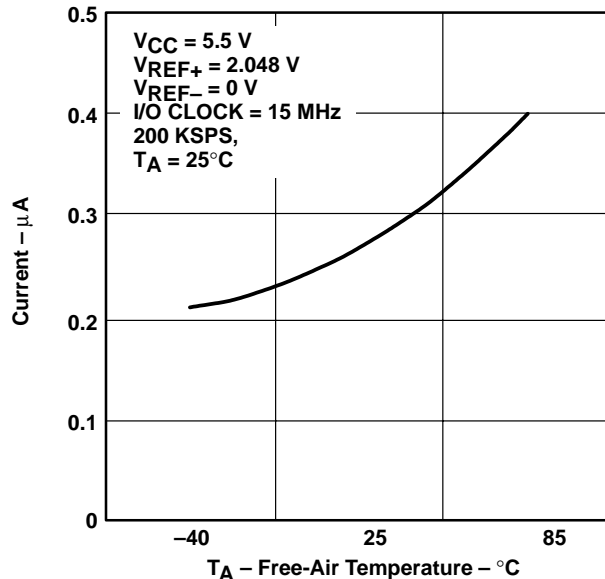

Figure 26

AUTO POWER DOWN
vs
FREE-AIR TEMPERATURE

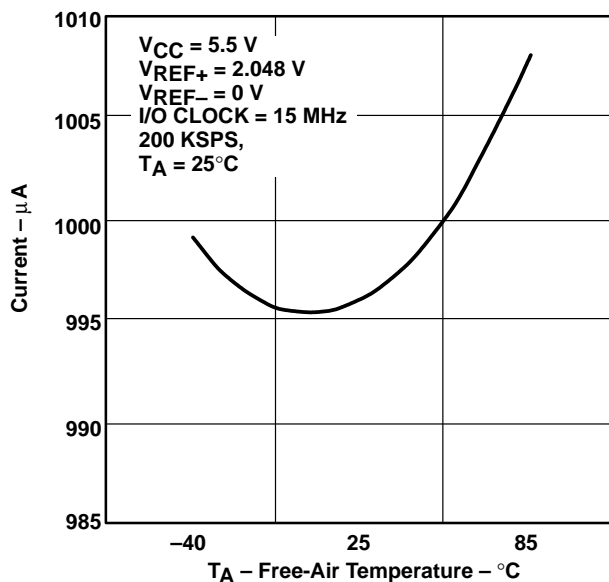

Figure 27

2-V INTERNAL REFERENCE CURRENT
vs
FREE-AIR TEMPERATURE

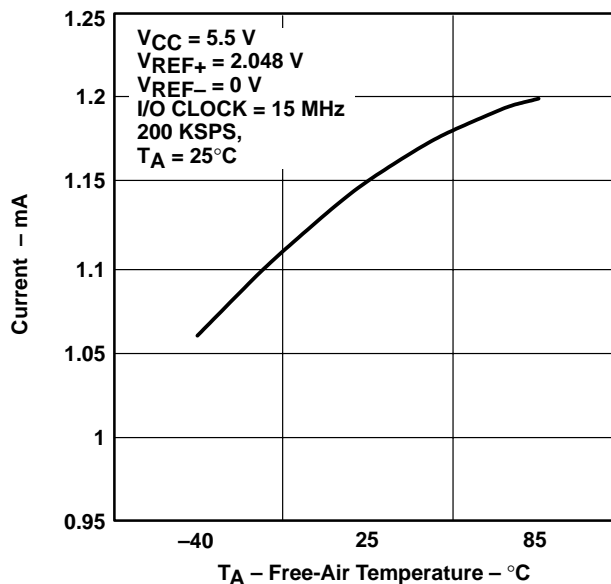

Figure 28

NOTE: All typical curves are with internal reference unless specified otherwise. Refer to the TLV2553 data sheet (SLAS354) for typical curves using an external reference.

TYPICAL CHARACTERISTICS

MAXIMUM DIFFERENTIAL NONLINEARITY
vs
FREE-AIR TEMPERATURE

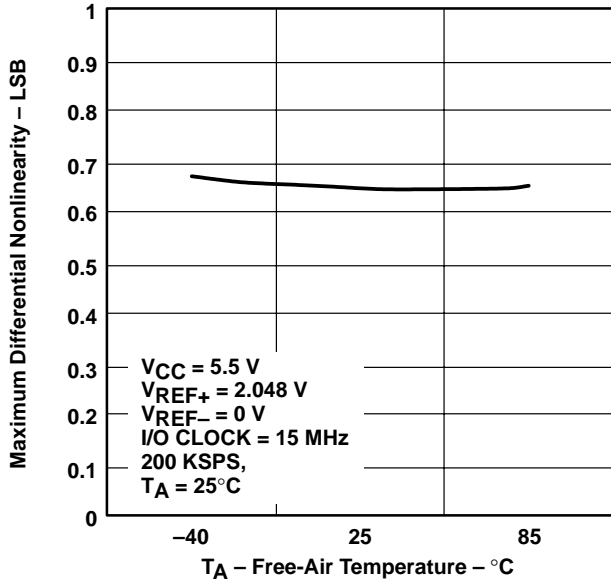

Figure 29

MINIMUM DIFFERENTIAL NONLINEARITY
vs
FREE-AIR TEMPERATURE

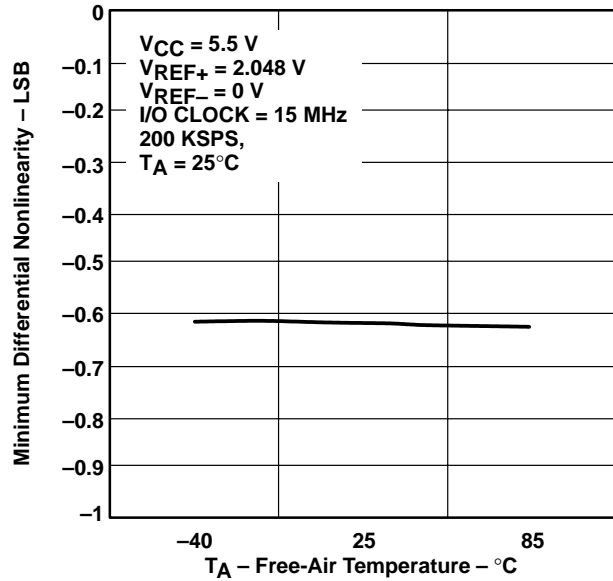

Figure 30

MAXIMUM INTEGRAL NONLINEARITY
vs
FREE-AIR TEMPERATURE

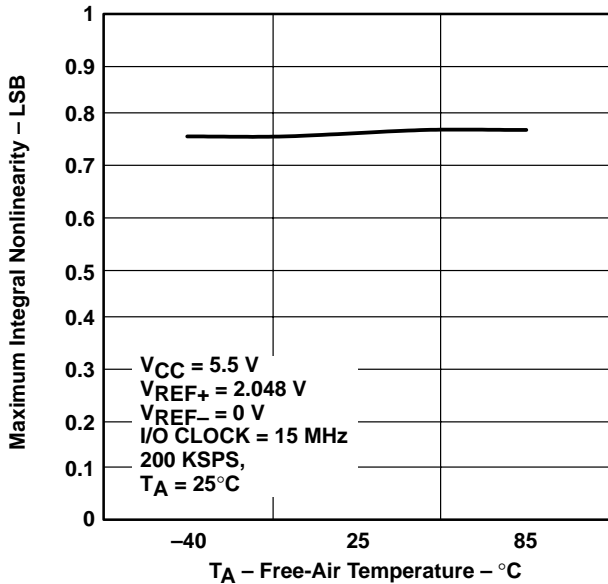

Figure 31

MINIMUM INTEGRAL NONLINEARITY
vs
FREE-AIR TEMPERATURE

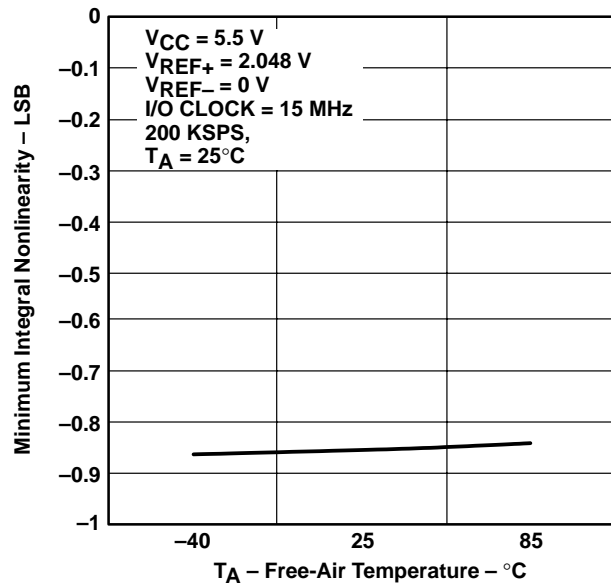
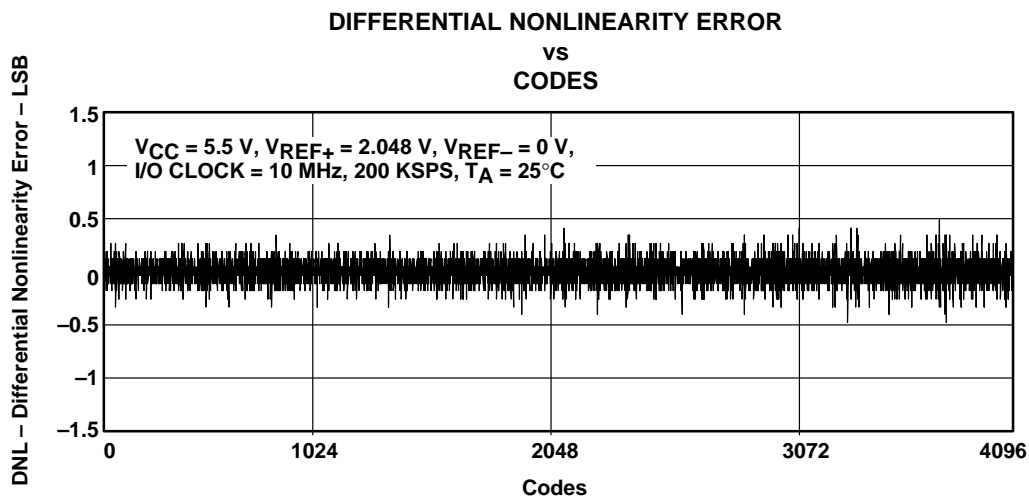
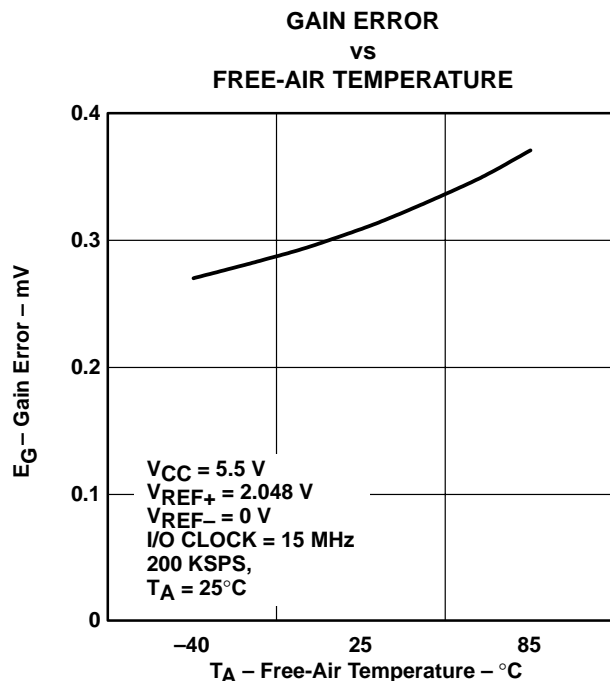
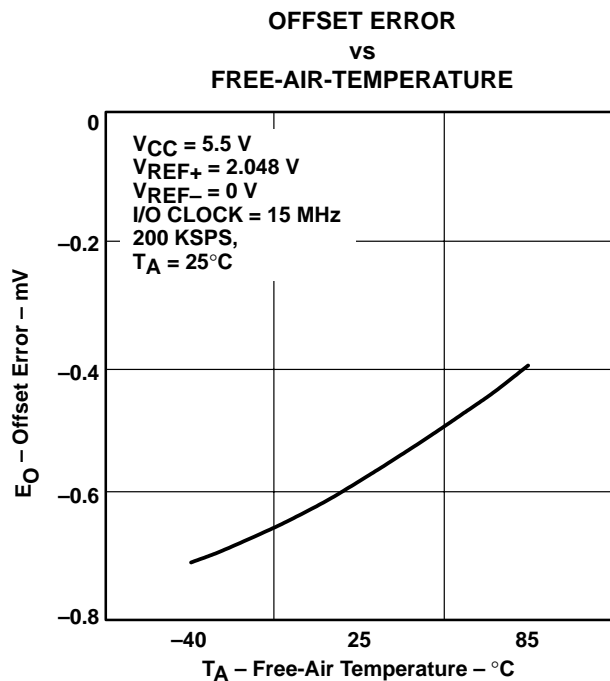

Figure 32

NOTE: All typical curves are with internal reference unless specified otherwise. Refer to the TLV2553 data sheet (SLAS354) for typical curves using an external reference.

TYPICAL CHARACTERISTICS



NOTE: All typical curves are with internal reference unless specified otherwise. Refer to the TLV2553 data sheet (SLAS354) for typical curves using an external reference.

TYPICAL CHARACTERISTICS

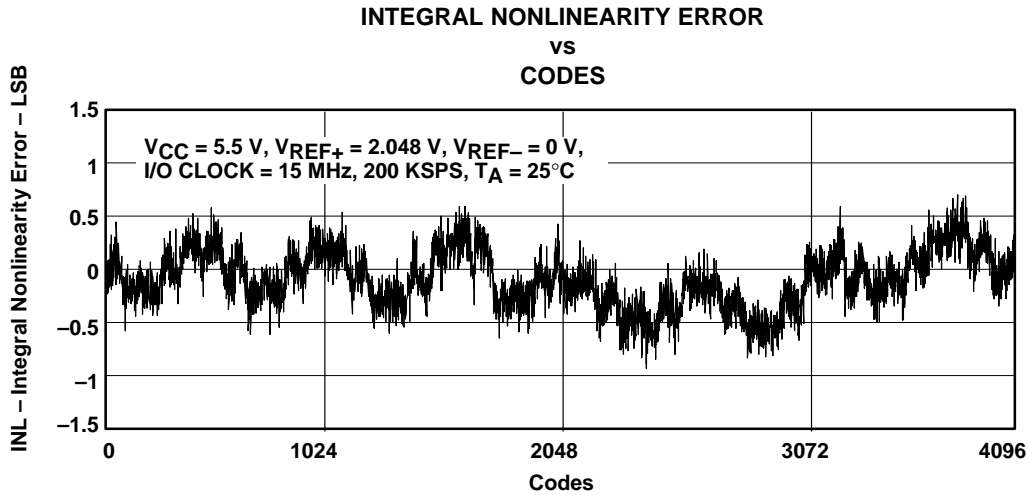

Figure 36

NOTE: All typical curves are with internal reference unless specified otherwise. Refer to the TLV2553 data sheet (SLAS354) for typical curves using an external reference.

PARAMETER MEASUREMENT INFORMATION

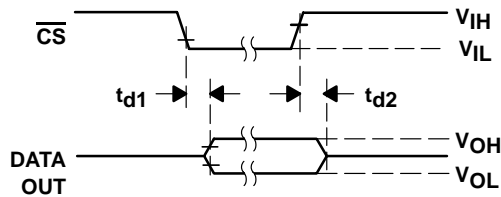

Figure 37. DATA OUT to Hi-Z Voltage Waveforms

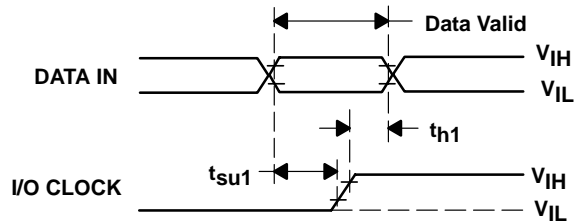

Figure 38. DATA IN and I/O CLOCK Voltage

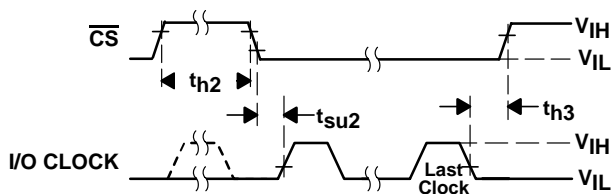

Figure 39. \overline{CS} and I/O CLOCK Voltage Waveforms

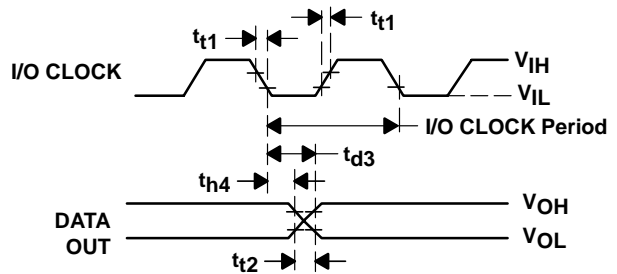

Figure 40. I/O CLOCK and DATA OUT Voltage Waveforms

PARAMETER MEASUREMENT INFORMATION

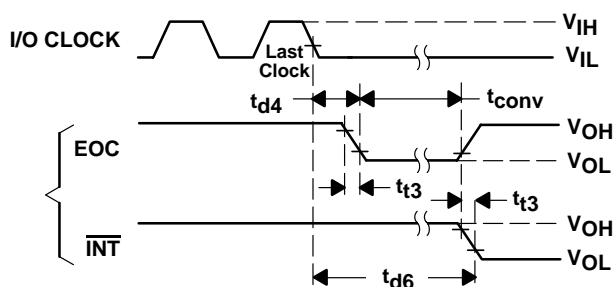

Figure 41. I/O CLOCK and EOC Voltage Waveforms

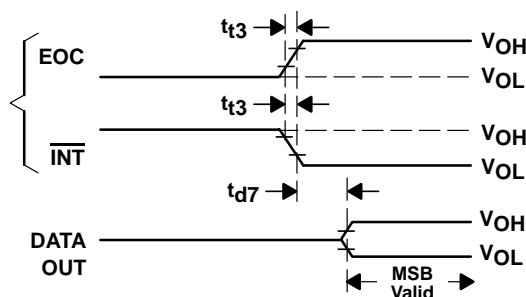

Figure 42. EOC and DATA OUT Voltage Waveforms

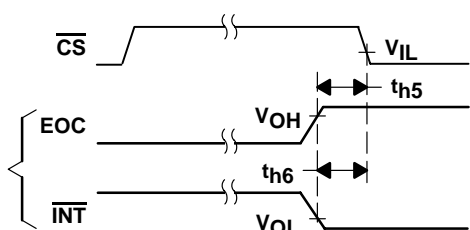

Figure 43. CS and EOC Voltage Waveforms

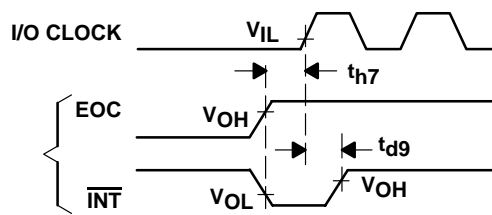
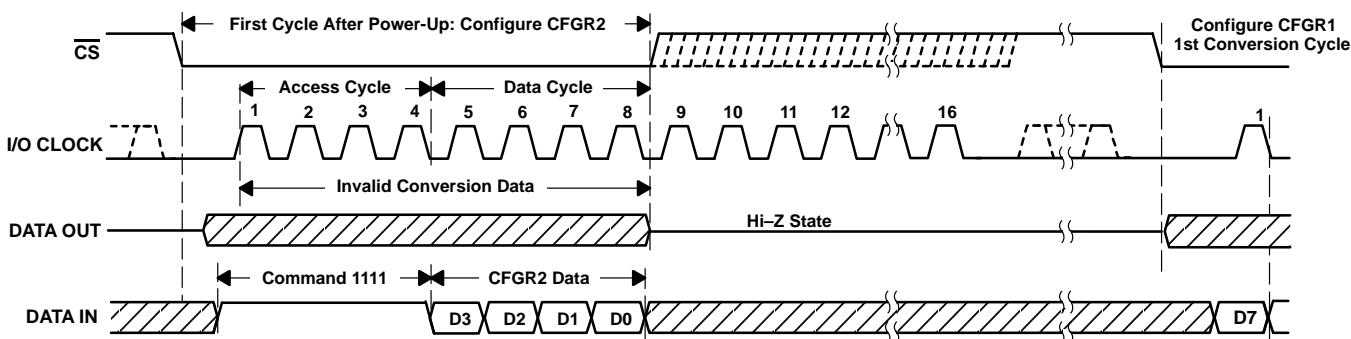

Figure 44. I/O CLOCK and EOC Voltage Waveforms

timing information



NOTE A: To minimize errors caused by noise at CS, the internal circuitry waits for a setup time after the CS falling edge before responding to control input signals. Therefore, no attempt should be made to clock in an address until the minimum CS setup time has elapsed.

Figure 45. Timing for CFGR2 Configuration

The host must configure CFGR2 before valid device conversions can begin. This can be accessed through command 1111. This can be done using eight, twelve, or sixteen I/O CLOCK clocks. (A minimum of eight is required to fully program CFGR2.)

After CFGR2 is configured, the following cycle configures CFGR1 and a valid sample/conversion is performed. CS can be held low for each remaining cycle. First valid conversion output data is available on the third cycle after power up.

PARAMETER MEASUREMENT INFORMATION

timing diagrams

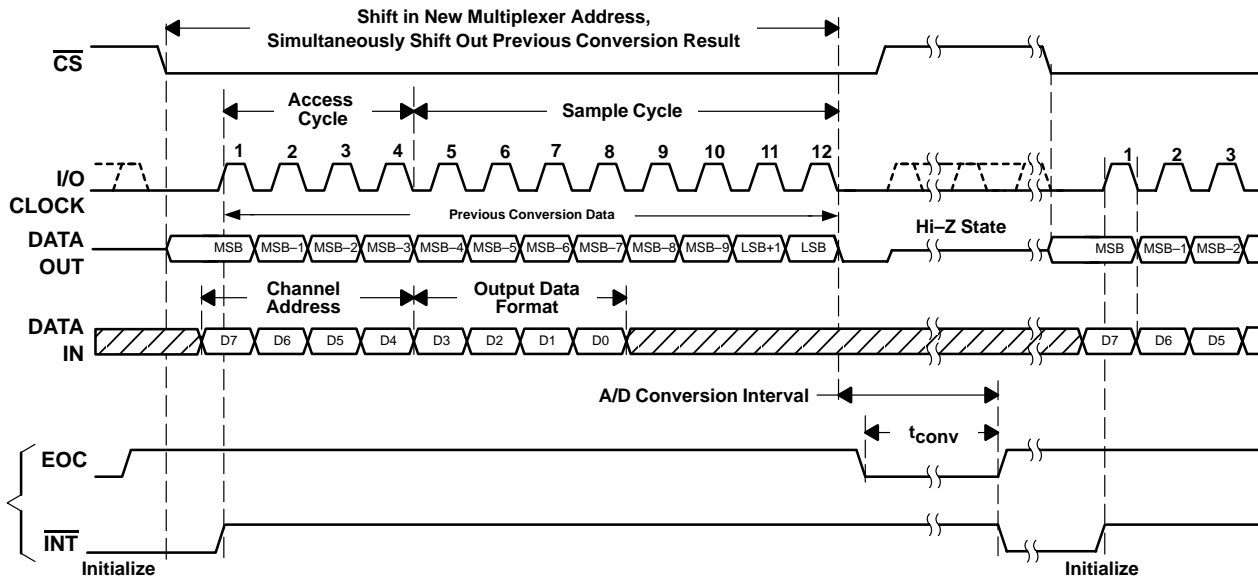

NOTE A: To minimize errors caused by noise at \overline{CS} , the internal circuitry waits for a setup time after the \overline{CS} falling edge before responding to control input signals. Therefore, no attempt should be made to clock in an address until the minimum \overline{CS} setup time has elapsed.

Figure 46. Timing for 12-Clock Transfer Using \overline{CS} With DATA OUT Set for MSB First

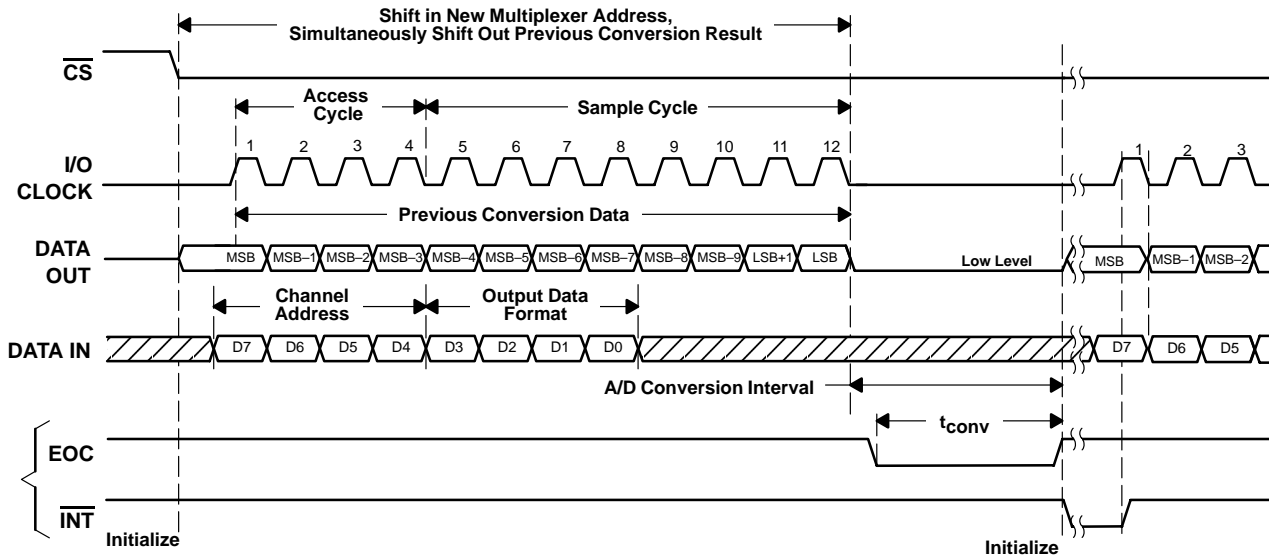

NOTE A: To minimize errors caused by noise at \overline{CS} , the internal circuitry waits for a setup time after the \overline{CS} falling edge before responding to control input signals. Therefore, no attempt should be made to clock in an address until the minimum \overline{CS} setup time has elapsed.

Figure 47. Timing for 12-Clock Transfer Not Using \overline{CS} With DATA OUT Set for MSB First

PARAMETER MEASUREMENT INFORMATION

timing diagrams (continued)

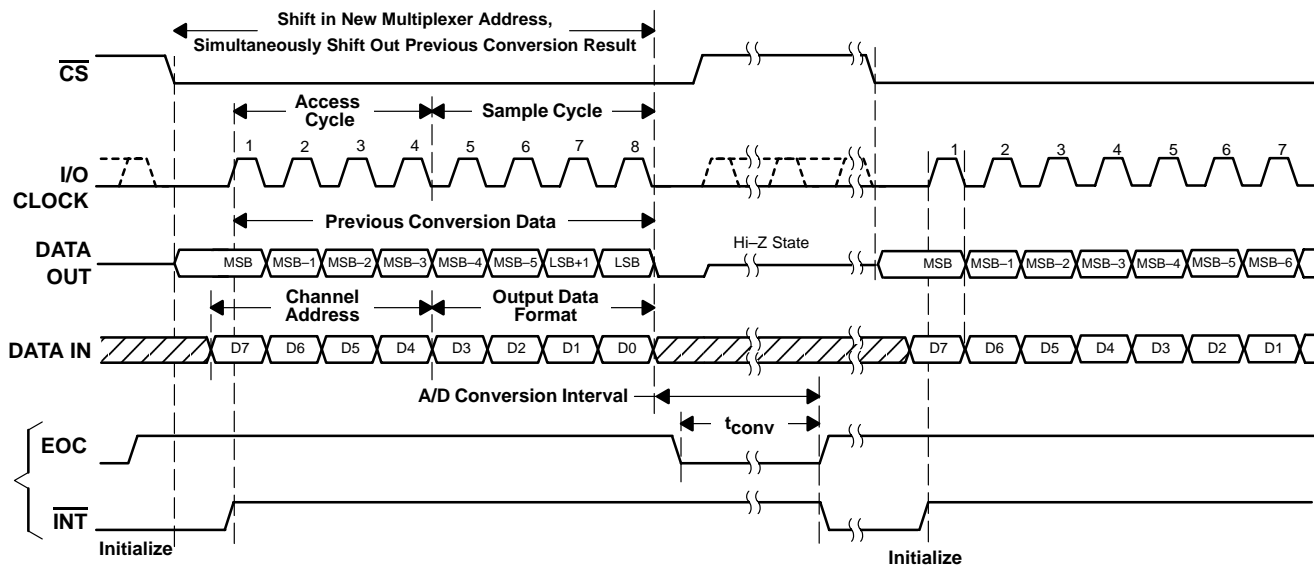

NOTE A: To minimize errors caused by noise at \overline{CS} , the internal circuitry waits for a setup time after the \overline{CS} falling edge before responding to control input signals. Therefore, no attempt should be made to clock in an address until the minimum \overline{CS} setup time has elapsed.

Figure 48. Timing for 8-Clock Transfer Using \overline{CS} With DATA OUT Set for MSB First

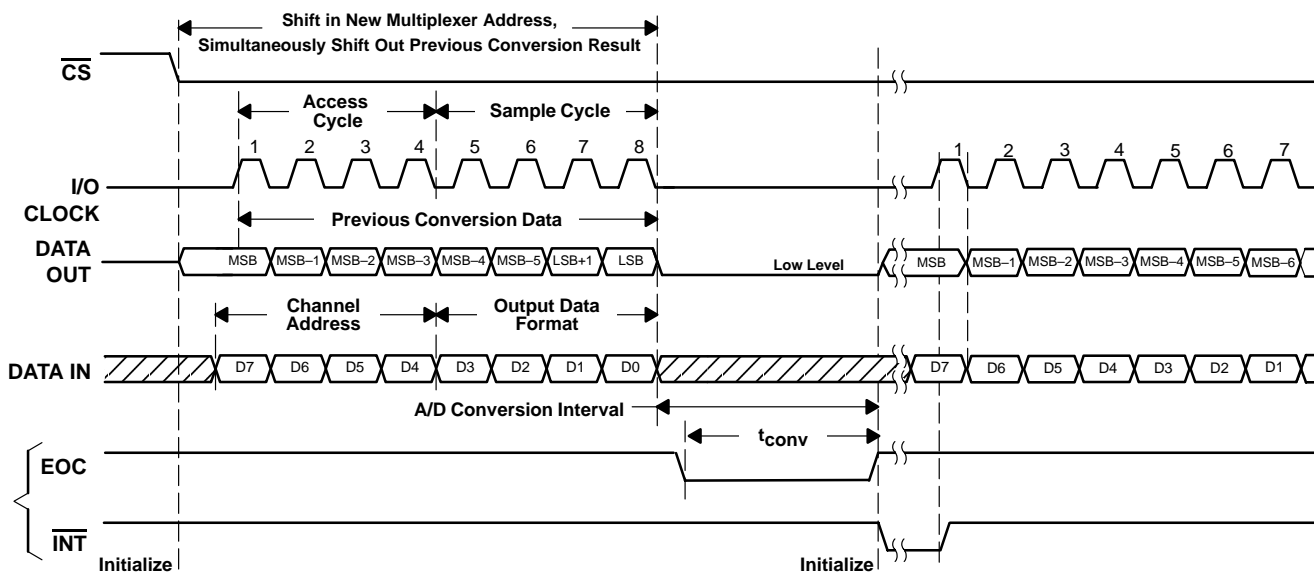

NOTE A: To minimize errors caused by noise at \overline{CS} , the internal circuitry waits for a setup time after the \overline{CS} falling edge before responding to control input signals. Therefore, no attempt should be made to clock in an address until the minimum \overline{CS} setup time has elapsed.

Figure 49. Timing for 8-Clock Transfer Not Using \overline{CS} With DATA OUT Set for MSB First

PARAMETER MEASUREMENT INFORMATION

timing diagrams (continued)

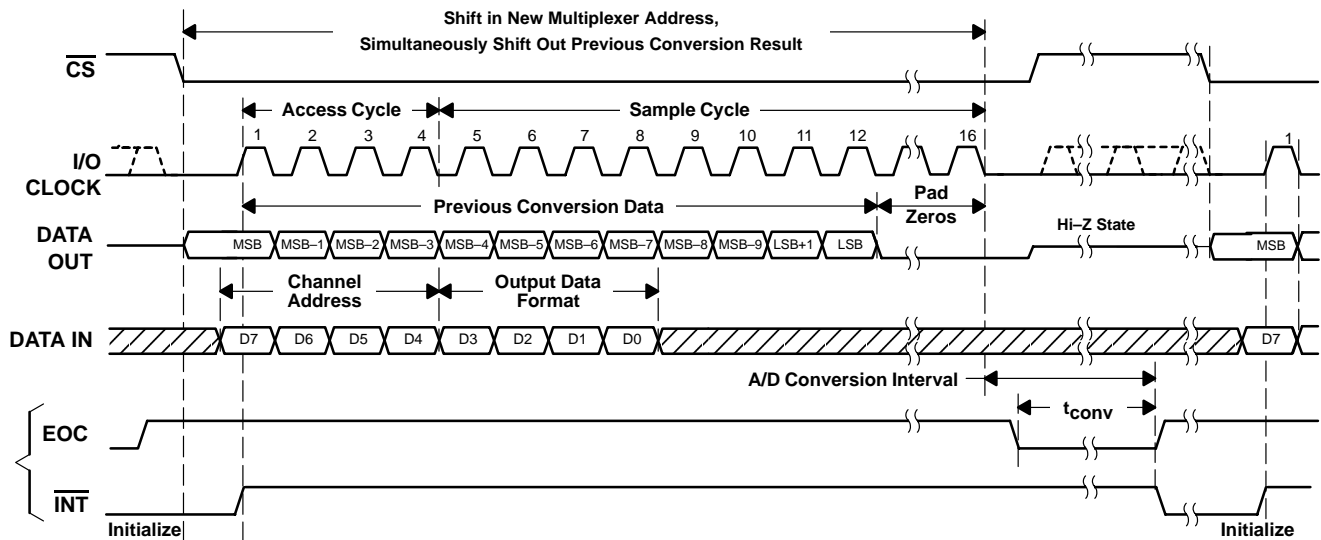

NOTE A: To minimize errors caused by noise at \overline{CS} , the internal circuitry waits for a setup time after the \overline{CS} falling edge before responding to control input signals. Therefore, no attempt should be made to clock in an address until the minimum \overline{CS} setup time has elapsed.

Figure 50. Timing for 16-Clock Transfer Using \overline{CS} With DATA OUT Set for MSB First

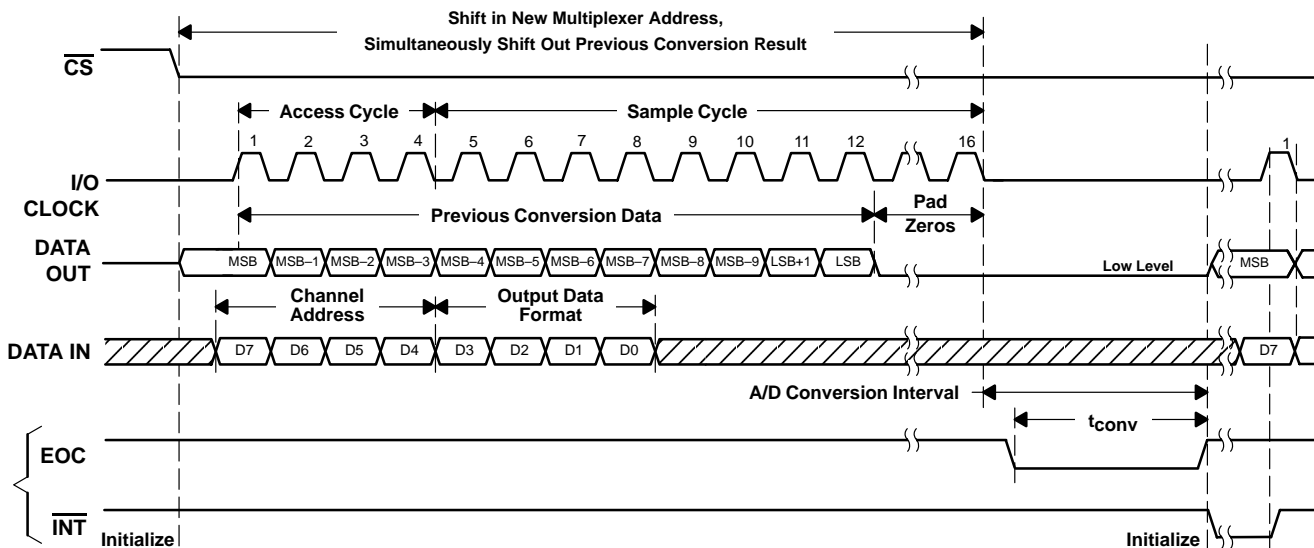
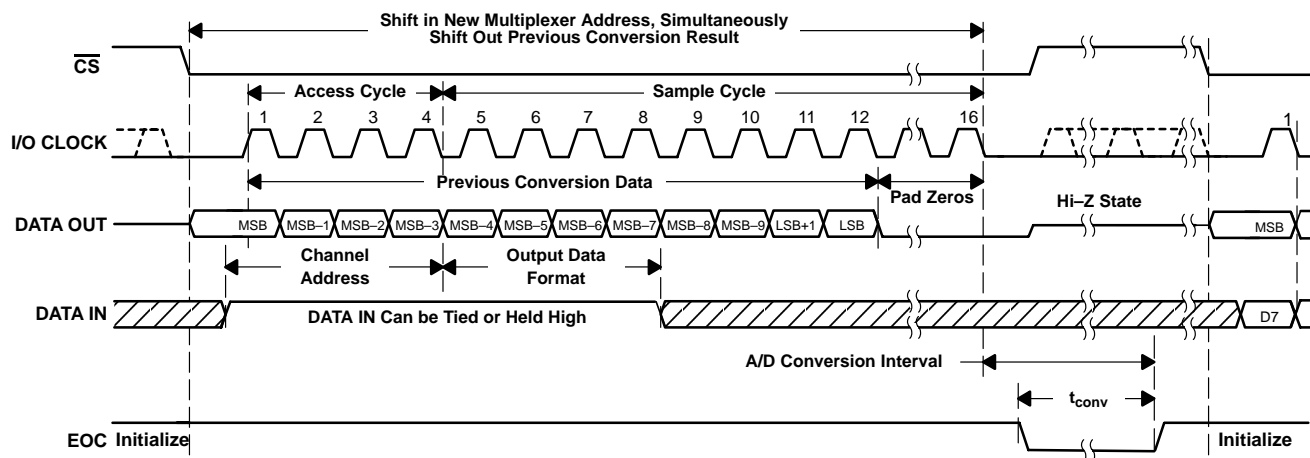

Figure 51. Timing for 16-Clock Transfer Not Using \overline{CS} With DATA OUT Set for MSB First

PARAMETER MEASUREMENT INFORMATION

timing diagrams (continued)



NOTE A: To minimize errors caused by noise at $\overline{\text{CS}}$, the internal circuitry waits for a setup time after the $\overline{\text{CS}}$ falling edge before responding to control input signals. Therefore, no attempt should be made to clock in an address until the minimum $\overline{\text{CS}}$ setup time has elapsed.

Figure 52. Timing for Default Mode Using $\overline{\text{CS}}$: (16-Clock Transfer, MSB First, Ext. Ref, Pin 19 = $\overline{\text{EOC}}$, Input = AIN0)

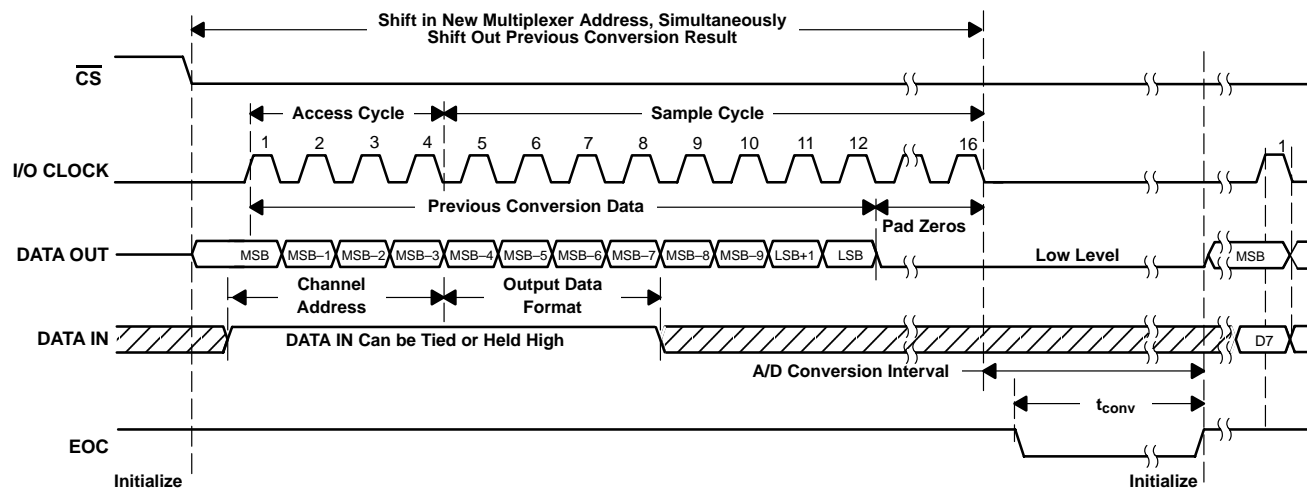

NOTE A: To minimize errors caused by noise at $\overline{\text{CS}}$, the internal circuitry waits for a setup time after the $\overline{\text{CS}}$ falling edge before responding to control input signals. Therefore, no attempt should be made to clock in an address until the minimum $\overline{\text{CS}}$ setup time has elapsed.

Figure 53. Timing for Default Mode Not Using $\overline{\text{CS}}$: (16-Clock Transfer, MSB First Ext. Ref, Pin 19 = $\overline{\text{EOC}}$, Input = AIN0)

To remove the device from default mode, CFG2–D0 must be reset to 0. Valid sample/convert cycles can resume on the cycle following the CFG2 configuration.

PRINCIPLES OF OPERATION

Initially, with chip select (\overline{CS}) high, I/O CLOCK and DATA IN are disabled and DATA OUT is in the high-impedance state. \overline{CS} going low begins the conversion sequence by enabling I/O CLOCK and DATA IN and removes DATA OUT from the high-impedance state. The input data is an 8-bit data stream consisting of a 4-bit address or command (D7–D4) and a 4-bit configuration data (D3–D0). There are two sets of configuration registers, configuration register 1 – CFGR1 and configuration register 2 – CFGR2. CFGR1, which controls output data format configuration, consists of a 2-bit data length select (D3–D2), an output MSB or LSB first bit (D1), and a unipolar or bipolar output select bit (D0) that are applied to any command (from DATA IN) except for command 1111b. CFGR2, which provides configuration information other than data format, consists of a 2-bit reference select (D3–D2), an EOC/ \overline{INT} program bit (D1), and a default mode select bit (D0) that are applied to command 1111b. The I/O CLOCK sequence applied to the I/O CLOCK terminal transfers this data to the input data register. During this transfer, the I/O CLOCK sequence also shifts the previous conversion result from the output data register to DATA OUT. I/O CLOCK receives the input sequence of 8, 12, or 16 clock cycles long depending on the data-length selection in the input data register. Sampling of the analog input begins on the fourth falling edge of the input I/O CLOCK sequence and is held after the last falling edge of the I/O CLOCK sequence. The last falling edge of the I/O CLOCK sequence also takes EOC low (if pin 19 = EOC) and begins the conversion.

converter operation

The operation of the converter is organized as a succession of three distinct cycles: 1) the data I/O cycle, 2) the sampling cycle and 3) the conversion cycle. The first two are partially overlapped.

data I/O cycle

The data I/O cycle is defined by the externally provided I/O CLOCK and lasts 8, 12, or 16 clock periods, depending on the selected output data length. During the I/O cycle, the following two operations take place simultaneously. An 8-bit data stream consisting of address/command and configuration information is provided to DATA IN. This data is shifted into the device on the rising edge of the first eight I/O CLOCK clocks. Data input is ignored after the first eight clocks during 12- or 16-clock I/O transfers. The data output, with a length of 8, 12, or 16 bits, is provided serially on DATA OUT. When \overline{CS} is held low, the first output data bit occurs on the rising edge of EOC. When \overline{CS} is toggled between conversions, the first output data bit occurs on the falling edge of \overline{CS} . This data is the result of the previous conversion period, and after the first output data bit, each succeeding bit is clocked out on the falling edge of each succeeding I/O CLOCK.

sampling period

During the sampling period, one of the analog inputs is internally connected to the capacitor array of the converter to store the analog input signal. The converter starts sampling the selected input immediately after the four address/command bits have been clocked into the input data register. Sampling starts on the fourth falling edge of I/O CLOCK. The converter remains in the sampling mode until the eighth, twelfth, or sixteenth falling edge of I/O CLOCK depending on the data-length selection.

After the 8-bit data stream has been clocked in, DATA IN should be held at a fixed digital level until EOC goes high or INT goes low (indicating that the conversion is complete) to maximize the sampling accuracy and minimize the influence of external digital noise.

PRINCIPLES OF OPERATION

conversion cycle

A conversion cycle is started only after the I/O cycle is completed, which minimizes the influence of external digital noise on the accuracy of the conversion. This cycle is transparent to the user because it is controlled by an internal clock (oscillator). The total conversion time is equal to 13.5 OSC clocks plus a small delay (~25 ns) to start the OSC. During the conversion period, the device performs a successive-approximation conversion on the analog input voltage.

When programmed as EOC, pin 19 goes low at the start of the conversion cycle and goes high when the conversion is complete and the output data register is latched. After EOC goes low, the analog input can be changed without affecting the conversion result. Since the delay from the falling edge of the last I/O CLOCK to the falling edge of EOC is fixed, any time-varying analog input signals can be digitized at a fixed rate without introducing systematic harmonic distortion or noise due to timing uncertainty.

When programmed as $\overline{\text{INT}}$, pin 19 goes low when the conversion is complete and the output data register is latched. The next I/O CLOCK rising edge clears the $\overline{\text{INT}}$ output. The time from the last I/O CLOCK falling edge to the falling $\overline{\text{INT}}$ edge is equivalent to the EOC delay mentioned above plus the maximum conversion time. $\overline{\text{INT}}$ is cancelled by (or brought to high) by either the next $\overline{\text{CS}}$ falling edge or the next SCLK rising edge (when $\overline{\text{CS}}$ is held low all of the time for multiple cycles). When $\overline{\text{CS}}$ is held low continuously (for multiple cycles) MSB output occurs after the first rising edge of I/O CLOCK after EOC is inactive or the falling edge of $\overline{\text{INT}}$.

power up and initialization

After power up, $\overline{\text{CS}}$ must be taken from high to low to begin an I/O cycle. $\overline{\text{INT}}$ /EOC pin is initially high, and both configuration registers are set to all zeroes. The contents of the output data register are random, and the first conversion result should be ignored. To initialize during operation, $\overline{\text{CS}}$ is taken high and is then returned low to begin the next I/O cycle. The first conversion after the device has returned from the power-down state may not read accurately due to internal device settling.

Table 1. Operational Terminology

Current (N) I/O cycle	The entire I/O CLOCK sequence that transfers address and control data into the data register and clocks the digital result from the previous conversion from DATA OUT.
Current (N) conversion cycle	The conversion cycle starts immediately after the current I/O cycle. The end of the current I/O cycle is the last clock falling edge in the I/O CLOCK sequence. The current conversion result is loaded into the output register when conversion is complete.
Current (N) conversion result	The current conversion result is serially shifted out on the next I/O cycle.
Previous (N-1) conversion cycle	The conversion cycle just prior to the current I/O cycle
Next (N+1) I/O cycle	The I/O period that follows the current conversion cycle

Example:

In 12-bit mode, the result of the current conversion cycle is a 12-bit serial-data stream clocked out during the next I/O cycle. The current I/O cycle must be exactly 12 bits long to maintain synchronization, even when this corrupts the output data from the previous conversion. The current conversion is begun immediately after the twelfth falling edge of the current I/O cycle.

PRINCIPLES OF OPERATION

default mode

When the DATA IN pin is held high, the ADC goes into hardware default mode because the CFGR2 bits are all programmed to the default values after 8 I/O CLOCKS. This means the ADC is programmed for an external reference and pin 19 as EOC. In addition, channel AIN0 is selected. The first conversion is invalid therefore the conversion result should be ignored. On the next cycle, AIN0 is sampled and converted. This mode of operation is valid when CS is toggled or held low after the first cycle.

To remove the device from hardware default mode, CFGR2 bit D0 must be reset to 0. Once this is done, the host must program CFGR1 on the next cycle and disregard the result from the current cycle's conversion.

data input

The data input is internally connected to an 8-bit serial-input address and control register. The register defines the operation of the converter and the output data length. The host provides the input data byte with the MSB first. Each data bit is clocked in on the rising edge of the I/O CLOCK sequence (see Table 2 for the data input-register format).

Table 2. Command Set (CMR) and Configuration

SDI D[7:4]		COMMAND
Binary,	HEX	
0000b	0h	SELECT analog input channel 0
0001b	1h	SELECT analog input channel 1
0010b	2h	SELECT analog input channel 2
0011b	3h	SELECT analog input channel 3
0100b	4h	SELECT analog input channel 4
0101b	5h	SELECT analog input channel 5
0110b	6h	SELECT analog input channel 6
0111b	7h	SELECT analog input channel 7
1000b	8h	SELECT analog input channel 8
1001b	9h	SELECT analog input channel 9
1010b	Ah	SELECT analog input channel 10
1011b	Bh	SELECT TEST, Voltage = (VREF+ + VREF-)/2
1100b	Ch	SELECT TEST, Voltage = REFM
1101b	Dh	SELECT TEST, Voltage = REFP
1110b	Eh	SW POWERDOWN (analog + reference)
1111b	Fh	ACCESS CFGR2

CFGR1	
SDI D[3:0]	CONFIGURATION
D[3:2]	01: 8-bit output length X0: 12-bit output length 11: 16-bit output length (default)
D1	0: MSB out first (default) 1: LSB out first
D0	0: Unipolar binary (default) 1: Bipolar 2s complement

CFGR2	
SDI D[3:0]	CONFIGURATION
D[3:2]	00: Internal 4.096 reference 01: Internal 2.048 reference 11: External reference (default)
D1	0: Pin 19 output EOC (default) 1: Pin 19 output Int
D0	0: Normal mode (CFGR1 needs to be programmed) 1: Default mode enabled (D[3:0] of CFGR1 and D[3:1] of CFGR2 set to default)

PRINCIPLES OF OPERATION

data input—address/command bits

The four MSBs (D7–D4) of the input data register are the address or command. These bits can be used to address one of the 11 input channels, select one of three reference-test voltages, activate the software power-down mode, or access the second configuration register, CFGR2. All address/command bits affect the current conversion, which is the conversion that immediately follows the current I/O cycle. They also allow access to CFGR1 except for command 1111b, which allows access to CFGR2.

data output length

CFGR1 bits (D3 and D2) of the data register select the output data length. The data-length selection is valid for the current I/O cycle (the cycle in which the data is read). The data-length selection, being valid for the current I/O cycle, allows device start-up without losing I/O synchronization. A data length of 8, 12, or 16 bits can be selected. Since the converter has 12-bit resolution, a data length of 12 bits is suggested.

With D3 and D2 set to 00 or 10, the device is in the 12-bit data-length mode and the result of the current conversion is output as a 12-bit serial data stream during the next I/O cycle. The current I/O cycle must be exactly 12 bits long for proper synchronization, even when this means corrupting the output data from a previous conversion. The current conversion is started immediately after the twelfth falling edge of the current I/O cycle.

With bits D3 and D2 set to 11, the 16-bit data-length mode is selected, which allows convenient communication with 16-bit serial interfaces. In the 16-bit mode, the result of the current conversion is output as a 16-bit serial data stream during the next I/O cycle with the four LSBs always reset to 0 (pad bits). The current I/O cycle must be exactly 16 bits long to maintain synchronization even when this means corrupting the output data from the previous conversion. The current conversion is started immediately after the sixteenth falling edge of the current I/O cycle.

With bits D3 and D2 set to 01, the 8-bit data-length mode is selected, which allows fast communication with 8-bit serial interfaces. In the 8-bit mode, the result of the current conversion is output as an 8-bit serial data stream during the next I/O cycle. The current I/O cycle must be exactly eight bits long to maintain synchronization, even when this means corrupting the output data from the previous conversion. The four LSBs of the conversion result are truncated and discarded. The current conversion is started immediately after the eighth falling edge of the current I/O cycle.

Since the D3 and D2 register settings take effect on the I/O cycle when the data length is programmed, there can be a conflict with the previous cycle if the data-word length was changed. This may occur when the data format is selected to be least significant bit first, since at the time the data length change becomes effective (six rising edges of I/O CLOCK), the previous conversion result has already started shifting out. In actual operation, when different data lengths are required within an application and the data length is changed between two conversions, no more than one conversion result can be corrupted and only when it is shifted out in LSB-first format.

LSB out first

D1 in the CFGR1 controls the direction of the output (binary) data transfer. When D1 is reset to 0, the conversion result is shifted out MSB first. When set to 1, the data is shifted out LSB first. Selection of MSB first or LSB first always affects the next I/O cycle and not the current I/O cycle. When changing from one data direction to another, the current I/O cycle is never disrupted.

PRINCIPLES OF OPERATION

bipolar output format

D0 in the CFGR1 controls the binary data format used to represent the conversion result. When D0 is cleared to 0, the conversion result is represented as unipolar (unsigned binary) data. Nominally, the conversion result of an input voltage equal to or less than V_{REF-} is a code with all zeros (000 . . . 0) and the conversion result of an input voltage equal to or greater than V_{REF+} is a code of all ones (111 . . . 1). The conversion result of $(V_{REF+} + V_{REF-})/2$ is a code of a one followed by zeros (100 ...0).

When D0 is set to 1, the conversion result is represented as bipolar (signed binary) data. Nominally, conversion of an input voltage equal to or less than V_{REF-} is a code of a one followed by zeros (100 . . . 0), and the conversion of an input voltage equal to or greater than V_{REF+} is a code of a zero followed by all ones (011 . . . 1). The conversion result of $(V_{REF+} + V_{REF-})/2$ is a code of all zeros (000 . . . 0). The MSB is interpreted as the sign bit. The bipolar data format is related to the unipolar format in that the MSBs are always each other's complement.

Selection of the unipolar or bipolar format always affects the current conversion cycle, and the result is output during the next I/O cycle. When changing between unipolar and bipolar formats, the data output during the current I/O cycle is not affected.

reference

The device has a built-in reference with a programmable level of 2.048 V or 4.096 V. If the internal reference is used, REF+ is set to 2.048 V or 4.096 V and REF– is set to analog GND. An external reference can also be used through two reference input pins, REF+ and REF–, if the reference source is programmed as external. The voltage levels applied to these pins establish the upper and lower limits of the analog inputs to produce a full-scale and zero-scale reading respectively. The values of REF+, REF–, and the analog input should not exceed the positive supply or be lower than GND consistent with the specified absolute maximum ratings. The digital output is at full scale when the input signal is equal to or higher than REF+ and at zero when the input signal is equal to or lower than REF–.

PRINCIPLES OF OPERATION

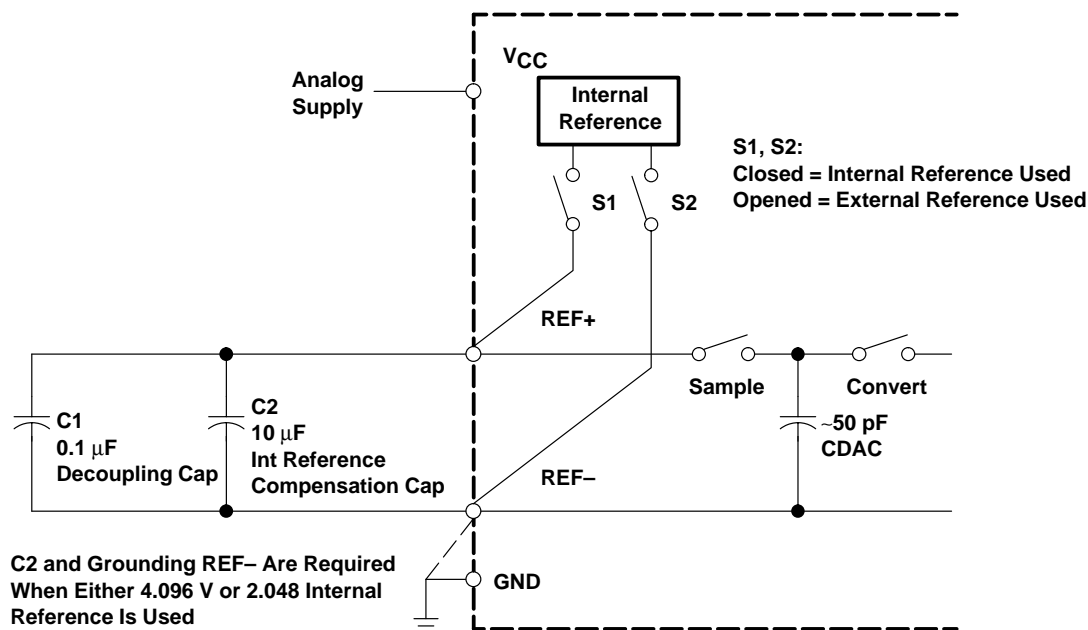

Figure 54. Reference Block

 $\overline{\text{INT}}/\text{EOC}$ output

Pin 19 outputs the status of the ADC conversion. When programmed as EOC, the output indicates the beginning and the end of conversion. In the reset state, EOC is always high. During the sampling period (beginning after the fourth falling edge of the I/O CLOCK sequence), EOC remains high until the internal sampling switch of the converter is safely opened. The opening of the sampling switch occurs after the eighth, twelfth, or sixteenth I/O CLOCK falling edge, depending on the data-length selection in the input data register. After the EOC signal goes low, the analog input signal can be changed without affecting the conversion result.

The EOC signal goes high again after the conversion is completed and the conversion result is latched into the output data register. The rising edge of EOC returns the converter to a reset state and a new I/O cycle begins. On the rising edge of EOC, the first bit of the current conversion result is on DATA OUT when $\overline{\text{CS}}$ is low. When $\overline{\text{CS}}$ is toggled between conversions, the first bit of the current conversion result occurs on DATA OUT at the falling edge of $\overline{\text{CS}}$.

When programmed as $\overline{\text{INT}}$, the output indicates that the conversion is completed and the output data is ready to be read. In the reset state, $\overline{\text{INT}}$ is always high. $\overline{\text{INT}}$ is high during the sampling period and until the conversion is complete. After the conversion is finished and the output data is latched, $\overline{\text{INT}}$ goes low and remains low until it is cleared by the host. When $\overline{\text{CS}}$ is held low, the MSB (or LSB) of the conversion result is presented on DATA OUT on the falling edge of $\overline{\text{INT}}$. A rising I/O CLOCK edge clears the interrupt.

PRINCIPLES OF OPERATION

chip-select input (\overline{CS})

\overline{CS} enables and disables the device. During normal operation, \overline{CS} should be low. Although the use of \overline{CS} is not necessary to synchronize a data transfer, it can be brought high between conversions to coordinate the data transfer of several devices sharing the same bus.

When \overline{CS} is brought high, the serial-data output is immediately brought to the high-impedance state, releasing its output data line to other devices that may share it. After an internally generated debounce time, I/O CLOCK is inhibited, thus preventing any further change in the internal state.

When \overline{CS} is subsequently brought low again, the device is reset. \overline{CS} must be held low for an internal debounce time before the reset operation takes effect. After \overline{CS} is debounced low, I/O CLOCK must remain inactive (low) for a minimum time before a new I/O cycle can start.

\overline{CS} can interrupt any ongoing data transfer or any ongoing conversion. When \overline{CS} is debounced low long enough before the end of the current conversion cycle, the previous conversion result is saved in the internal output buffer and shifted out during the next I/O cycle.

When \overline{CS} is held low continuously for multiple cycles, the first data bit of the newly completed conversion occurs on DATA OUT on the rising edge of EOC or falling edge of \overline{INT} . Note that the first cycle in the series still requires a transition of \overline{CS} from high to low. When a new conversion is started after the last falling edge of I/O CLOCK, EOC goes low and the serial output is forced low until EOC goes high again.

When \overline{CS} is toggled between conversions, the first data bit occurs on DATA OUT on the falling edge of \overline{CS} . On each subsequent falling edge of I/O CLOCK after the first data bit appears, the data is changed to the next bit in the serial conversion result until the required number of bits has been output.

power-down features

When command (D7–D4) 1110b is clocked into the input data register during the first four I/O CLOCK cycles, the software power-down mode is selected. Software power down is activated on the falling edge of the fourth I/O CLOCK pulse.

During software power down, all internal circuitry is put in a low-current standby mode. The internal reference (if being used) is powered down. No conversion is performed. The internal output buffer keeps the previous conversion cycle data results provided that all digital inputs are held above $V_{CC} - 0.5$ V or below 0.5 V. The I/O logic remains active so the current I/O cycle must be completed even when the power-down mode is selected. Upon power-on reset and before the first I/O cycle, the converter normally begins in the power-down mode. The device remains in the software power-down mode until a valid input address (other than command 1110b) is clocked in. Upon completion of that I/O cycle, a normal conversion is performed with the results being shifted out during the next I/O cycle. If using the internal reference, care must be taken to allow the reference to power on completely before a valid conversion can be performed. It requires 1 ms to resume from a software power down.

The ADC also has an auto power-down mode. This is transparent to users. The ADC goes into auto power down within 1 I/O CLOCK cycle after the conversion is complete and resumes, with a small delay after an active \overline{CS} is sent to the ADC. This mode keeps built-in reference so resumption is fast enough to be used between cycles.

analog MUX

The 11 analog inputs, three internal voltages, and power-down mode are selected by the input multiplexer according to the input addresses shown in Table 2. The input multiplexer is a break-before-make type to reduce input-to-input noise rejection resulting from channel switching. Sampling of the analog inputs starts on the falling edge of the fourth I/O CLOCK and continues for the remaining I/O CLOCK pulses. The sample is held on the falling edge of the last I/O CLOCK pulse. The three internal test inputs are applied to the multiplexer, then sampled and converted in the same manner as the external analog inputs. The first conversion after the device has returned from the power-down state may not read accurately due to internal device settling.

MECHANICAL DATA

DW (R-PDSO-G**)

PLASTIC SMALL-OUTLINE PACKAGE

16 PINS SHOWN

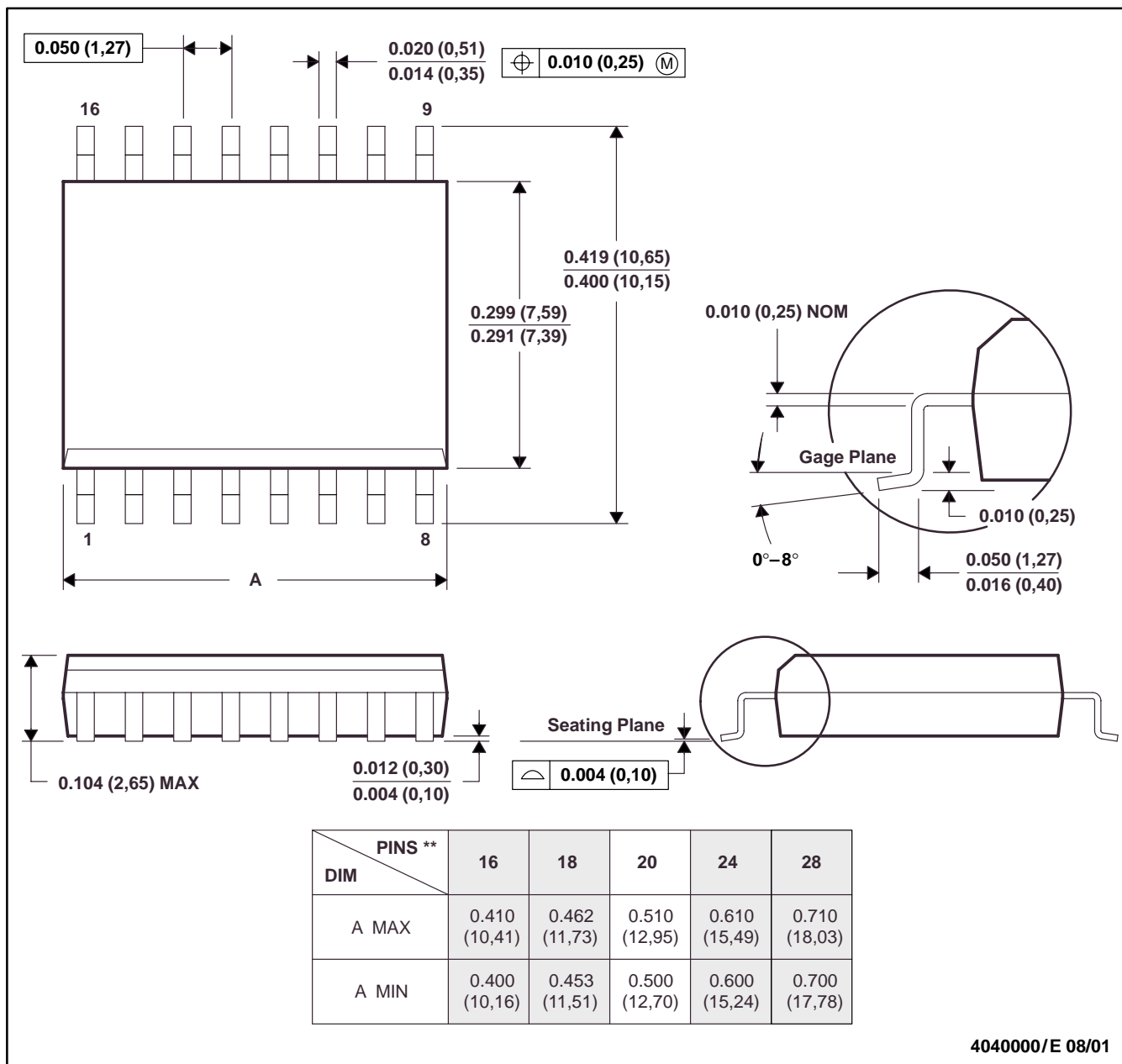

- NOTES: A. All linear dimensions are in inches (millimeters).
 B. This drawing is subject to change without notice.
 C. Body dimensions do not include mold flash or protrusion not to exceed 0.006 (0,15).
 D. Falls within JEDEC MS-013

TLV2556

SLAS355A – DECEMBER 2001 – REVISED SEPTEMBER 2002

MECHANICAL DATA

PW (R-PDSO-G**)

PLASTIC SMALL-OUTLINE PACKAGE

14 PINS SHOWN

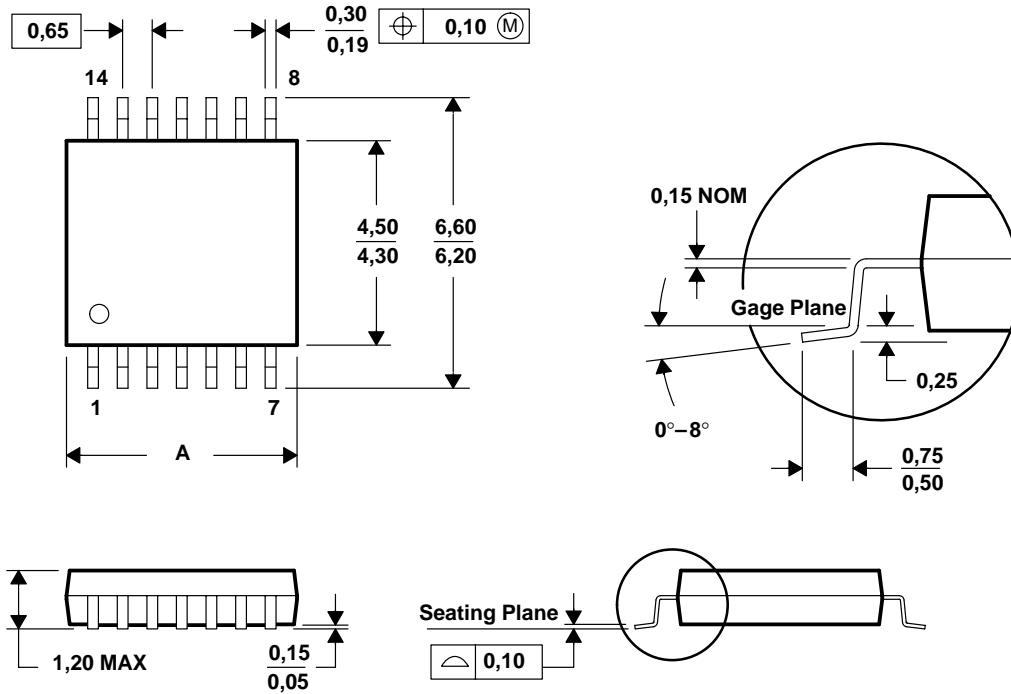

DIM \ PINS **	8	14	16	20	24	28
	A MAX	3,10	5,10	5,10	6,60	7,90
A MIN	2,90	4,90	4,90	6,40	7,70	9,60

4040064/F 01/97

- NOTES: A. All linear dimensions are in millimeters.
 B. This drawing is subject to change without notice.
 C. Body dimensions do not include mold flash or protrusion not to exceed 0,15.
 D. Falls within JEDEC MO-153

PACKAGING INFORMATION

Orderable Device	Status ⁽¹⁾	Package Type	Package Drawing	Pins	Package Qty	Eco Plan ⁽²⁾	Lead/Ball Finish	MSL Peak Temp ⁽³⁾
TLV2556IDW	ACTIVE	SOIC	DW	20	25	Green (RoHS & no Sb/Br)	CU NIPDAU	Level-1-260C-UNLIM
TLV2556IDWG4	ACTIVE	SOIC	DW	20	25	Green (RoHS & no Sb/Br)	CU NIPDAU	Level-1-260C-UNLIM
TLV2556IDWR	ACTIVE	SOIC	DW	20	2000	Green (RoHS & no Sb/Br)	CU NIPDAU	Level-1-260C-UNLIM
TLV2556IDWRG4	ACTIVE	SOIC	DW	20	2000	Green (RoHS & no Sb/Br)	CU NIPDAU	Level-1-260C-UNLIM
TLV2556IPW	ACTIVE	TSSOP	PW	20	70	Green (RoHS & no Sb/Br)	CU NIPDAU	Level-1-260C-UNLIM
TLV2556IPWG4	ACTIVE	TSSOP	PW	20	70	Green (RoHS & no Sb/Br)	CU NIPDAU	Level-1-260C-UNLIM
TLV2556IPWR	ACTIVE	TSSOP	PW	20	2000	Green (RoHS & no Sb/Br)	CU NIPDAU	Level-1-260C-UNLIM
TLV2556IPWRG4	ACTIVE	TSSOP	PW	20	2000	Green (RoHS & no Sb/Br)	CU NIPDAU	Level-1-260C-UNLIM

⁽¹⁾ The marketing status values are defined as follows:

ACTIVE: Product device recommended for new designs.

LIFEBUY: TI has announced that the device will be discontinued, and a lifetime-buy period is in effect.

NRND: Not recommended for new designs. Device is in production to support existing customers, but TI does not recommend using this part in a new design.

PREVIEW: Device has been announced but is not in production. Samples may or may not be available.

OBSOLETE: TI has discontinued the production of the device.

⁽²⁾ Eco Plan - The planned eco-friendly classification: Pb-Free (RoHS), Pb-Free (RoHS Exempt), or Green (RoHS & no Sb/Br) - please check <http://www.ti.com/productcontent> for the latest availability information and additional product content details.

TBD: The Pb-Free/Green conversion plan has not been defined.

Pb-Free (RoHS): TI's terms "Lead-Free" or "Pb-Free" mean semiconductor products that are compatible with the current RoHS requirements for all 6 substances, including the requirement that lead not exceed 0.1% by weight in homogeneous materials. Where designed to be soldered at high temperatures, TI Pb-Free products are suitable for use in specified lead-free processes.

Pb-Free (RoHS Exempt): This component has a RoHS exemption for either 1) lead-based flip-chip solder bumps used between the die and package, or 2) lead-based die adhesive used between the die and leadframe. The component is otherwise considered Pb-Free (RoHS compatible) as defined above.

Green (RoHS & no Sb/Br): TI defines "Green" to mean Pb-Free (RoHS compatible), and free of Bromine (Br) and Antimony (Sb) based flame retardants (Br or Sb do not exceed 0.1% by weight in homogeneous material)

⁽³⁾ MSL, Peak Temp. -- The Moisture Sensitivity Level rating according to the JEDEC industry standard classifications, and peak solder temperature.

Important Information and Disclaimer:The information provided on this page represents TI's knowledge and belief as of the date that it is provided. TI bases its knowledge and belief on information provided by third parties, and makes no representation or warranty as to the accuracy of such information. Efforts are underway to better integrate information from third parties. TI has taken and continues to take reasonable steps to provide representative and accurate information but may not have conducted destructive testing or chemical analysis on incoming materials and chemicals. TI and TI suppliers consider certain information to be proprietary, and thus CAS numbers and other limited information may not be available for release.

In no event shall TI's liability arising out of such information exceed the total purchase price of the TI part(s) at issue in this document sold by TI to Customer on an annual basis.

OTHER QUALIFIED VERSIONS OF TLV2556 :

- Enhanced Product: [TLV2556-EP](#)

NOTE: Qualified Version Definitions:

- Enhanced Product - Supports Defense, Aerospace and Medical Applications

TAPE AND REEL INFORMATION

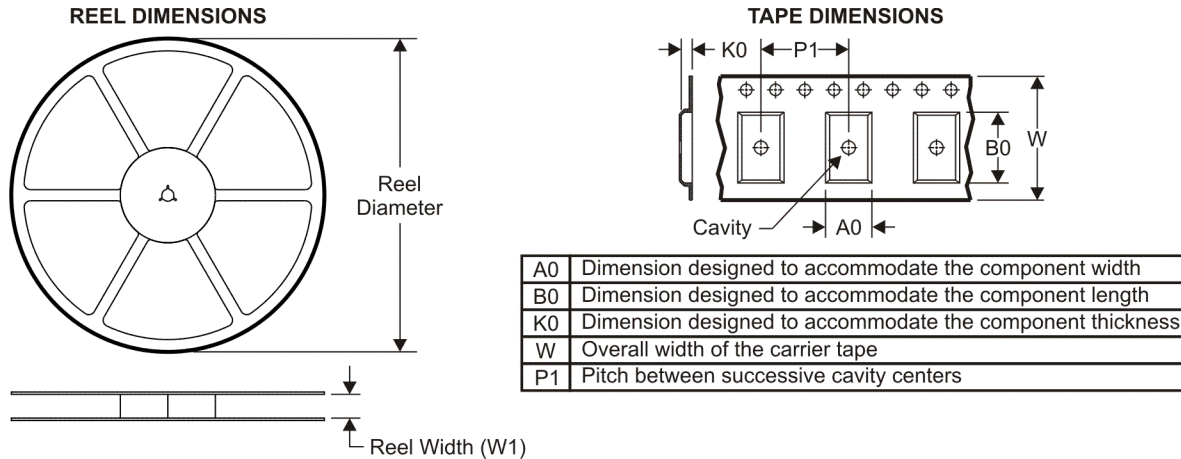

QUADRANT ASSIGNMENTS FOR PIN 1 ORIENTATION IN TAPE



*All dimensions are nominal

Device	Package Type	Package Drawing	Pins	SPQ	Reel Diameter (mm)	Reel Width W1 (mm)	A0 (mm)	B0 (mm)	K0 (mm)	P1 (mm)	W (mm)	Pin1 Quadrant
TLV2556IDWR	SOIC	DW	20	2000	330.0	24.4	10.8	13.1	2.65	12.0	24.0	Q1
TLV2556IPWR	TSSOP	PW	20	2000	330.0	16.4	6.95	7.1	1.6	8.0	16.0	Q1

TAPE AND REEL BOX DIMENSIONS



*All dimensions are nominal

Device	Package Type	Package Drawing	Pins	SPQ	Length (mm)	Width (mm)	Height (mm)
TLV2556IDWR	SOIC	DW	20	2000	346.0	346.0	41.0
TLV2556IPWR	TSSOP	PW	20	2000	346.0	346.0	33.0

IMPORTANT NOTICE

Texas Instruments Incorporated and its subsidiaries (TI) reserve the right to make corrections, modifications, enhancements, improvements, and other changes to its products and services at any time and to discontinue any product or service without notice. Customers should obtain the latest relevant information before placing orders and should verify that such information is current and complete. All products are sold subject to TI's terms and conditions of sale supplied at the time of order acknowledgment.

TI warrants performance of its hardware products to the specifications applicable at the time of sale in accordance with TI's standard warranty. Testing and other quality control techniques are used to the extent TI deems necessary to support this warranty. Except where mandated by government requirements, testing of all parameters of each product is not necessarily performed.

TI assumes no liability for applications assistance or customer product design. Customers are responsible for their products and applications using TI components. To minimize the risks associated with customer products and applications, customers should provide adequate design and operating safeguards.

TI does not warrant or represent that any license, either express or implied, is granted under any TI patent right, copyright, mask work right, or other TI intellectual property right relating to any combination, machine, or process in which TI products or services are used. Information published by TI regarding third-party products or services does not constitute a license from TI to use such products or services or a warranty or endorsement thereof. Use of such information may require a license from a third party under the patents or other intellectual property of the third party, or a license from TI under the patents or other intellectual property of TI.

Reproduction of TI information in TI data books or data sheets is permissible only if reproduction is without alteration and is accompanied by all associated warranties, conditions, limitations, and notices. Reproduction of this information with alteration is an unfair and deceptive business practice. TI is not responsible or liable for such altered documentation. Information of third parties may be subject to additional restrictions.

Resale of TI products or services with statements different from or beyond the parameters stated by TI for that product or service voids all express and any implied warranties for the associated TI product or service and is an unfair and deceptive business practice. TI is not responsible or liable for any such statements.

TI products are not authorized for use in safety-critical applications (such as life support) where a failure of the TI product would reasonably be expected to cause severe personal injury or death, unless officers of the parties have executed an agreement specifically governing such use. Buyers represent that they have all necessary expertise in the safety and regulatory ramifications of their applications, and acknowledge and agree that they are solely responsible for all legal, regulatory and safety-related requirements concerning their products and any use of TI products in such safety-critical applications, notwithstanding any applications-related information or support that may be provided by TI. Further, Buyers must fully indemnify TI and its representatives against any damages arising out of the use of TI products in such safety-critical applications.

TI products are neither designed nor intended for use in military/aerospace applications or environments unless the TI products are specifically designated by TI as military-grade or "enhanced plastic." Only products designated by TI as military-grade meet military specifications. Buyers acknowledge and agree that any such use of TI products which TI has not designated as military-grade is solely at the Buyer's risk, and that they are solely responsible for compliance with all legal and regulatory requirements in connection with such use.

TI products are neither designed nor intended for use in automotive applications or environments unless the specific TI products are designated by TI as compliant with ISO/TS 16949 requirements. Buyers acknowledge and agree that, if they use any non-designated products in automotive applications, TI will not be responsible for any failure to meet such requirements.

Following are URLs where you can obtain information on other Texas Instruments products and application solutions:

Products

Amplifiers	amplifier.ti.com
Data Converters	dataconverter.ti.com
DSP	dsp.ti.com
Clocks and Timers	www.ti.com/clocks
Interface	interface.ti.com
Logic	logic.ti.com
Power Mgmt	power.ti.com
Microcontrollers	microcontroller.ti.com
RFID	www.ti-rfid.com
RF/IF and ZigBee® Solutions	www.ti.com/lprf

Applications

Audio	www.ti.com/audio
Automotive	www.ti.com/automotive
Broadband	www.ti.com/broadband
Digital Control	www.ti.com/digitalcontrol
Medical	www.ti.com/medical
Military	www.ti.com/military
Optical Networking	www.ti.com/opticalnetwork
Security	www.ti.com/security
Telephony	www.ti.com/telephony
Video & Imaging	www.ti.com/video
Wireless	www.ti.com/wireless

Mailing Address: Texas Instruments, Post Office Box 655303, Dallas, Texas 75265
Copyright © 2008, Texas Instruments Incorporated